

Threading

Inserts

General turning

Aluminium
wheel turning

Automatic lathes

Ceramic tools

Parting and
grooving

Threading

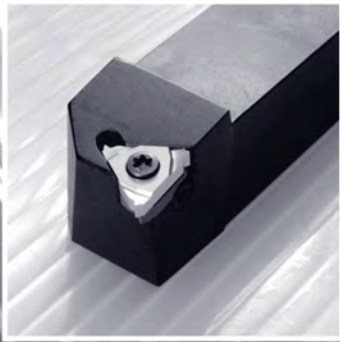

Threading

Code key	H.02
Threading inserts	H.03
Applications index	H.12
External threading	H.13
Internal threading	H.21
Technical information	H.28
Tooling for the petroleum industry	H.31

L 166 G - 3 B A 075

1 2 3 4 5 6 7

1

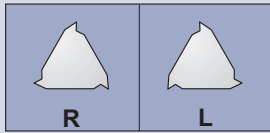

2



3

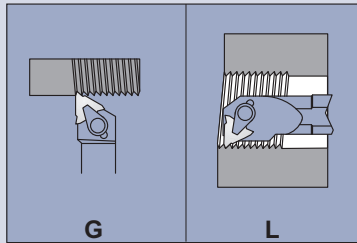

6

A	ISO mm.
C	SI
L	ISO Inch
K	Whitworth

4

	IC=Inch		D=mm.	
	2	1/4	6,35	11
	3	3/8	9,52	16
	4	1/2	12,70	22

5

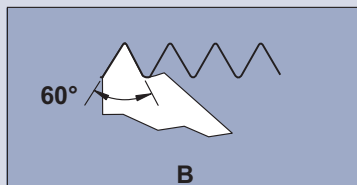

7

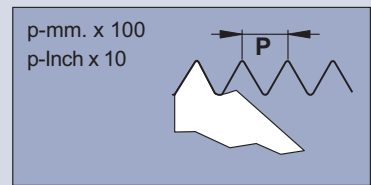

16 E L - AG 55

1 2 3 4 5

1

	IC=Inch		d=mm.	
	06	5/32	3,96	
	08	3/16	4,76	
	11	1/4	6,35	
	16	3/8	9,52	
	22	1/2	12,70	
	27	5/8	15,87	

2

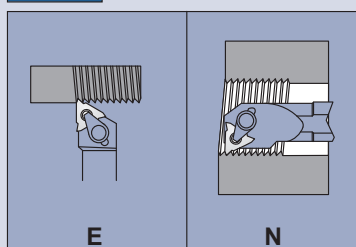

3

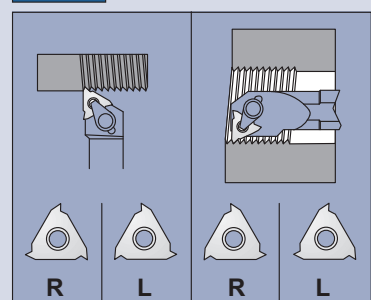

4

	p=mm. x 100		TPI
	p=Inch x 10		
	mm.		
A	0,5-1,5		48-16
AG	0,5-3,0		48-8
G	1,75-3,0		14-8
N	3,5-5,0		7-5

5

55	Partial profile 55°
60	Partial profile 60°
ISO	ISO metric
UN	American, UN
W	Whitworth, BSW
LG	Groove type LG

60° - 55° (non topping)

 <p>ER-60°/55° Triangular Negative Page H.04 0°</p>	 <p>EL-60°/55° Triangular Negative Page H.04 0°</p>	 <p>ER-60°/55° TD Triangular Negative Page H.04 0°</p>	 <p>NR-60°/55° Triangular Negative Page H.05 0°</p>	 <p>NL-60°/55° Triangular Negative Page H.05 0°</p>	 <p>NR-60°/55° TD Triangular Negative Page H.05 0°</p>	
---	---	--	---	--	--	--

ISO (full form) BS36

 <p>ER-ISO Triangular Negative Page H.06 0°</p>	 <p>EL-ISO Triangular Negative Page H.06 0°</p>	 <p>ER-ISO TD Triangular Negative Page H.06 0°</p>	 <p>EL-ISO TD Triangular Negative Page H.06 0°</p>	 <p>NR-ISO Triangular Negative Page H.07 0°</p>	 <p>NL-ISO Triangular Negative Page H.07 0°</p>	 <p>NR-ISO TD Triangular Negative Page H.07 0°</p>
---	---	--	--	--	---	--

UNIFIED (full form) ASME / ANSI B1.1

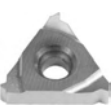
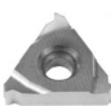
 <p>ER-UN Triangular Negative Page H.08 0°</p>	 <p>NR-UN Triangular Negative Page H.08 0°</p>					
---	---	--	--	--	--	--

WHITWORTH (full form) BS84

 <p>ER-W Triangular Negative Page H.08 0°</p>	 <p>EL-W Triangular Negative Page H.08 0°</p>	 <p>ER-W TD Triangular Negative Page H.08 0°</p>	 <p>NR-W Triangular Negative Page H.09 0°</p>	 <p>NL-W Triangular Negative Page H.09 0°</p>	 <p>NR-W TD Triangular Negative Page H.09 0°</p>	
---	---	--	---	--	--	--

Lock ring groove inserts type LG

 <p>ER-LG Triangular Negative Page H.10 0°</p>	 <p>EL-LG Triangular Negative Page H.10 0°</p>	
--	--	--

Others

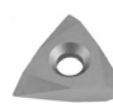
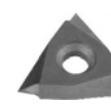
 <p>TNMC Triangular Negative Page H.10 0°</p>	 <p>TPMC Triangular Negative Page H.10 0°</p>	
--	---	--

ISO

 <p>L166G-ISO Triangular Positive Page H.11 7°</p>	 <p>R166G-ISO Triangular Positive Page H.11 7°</p>	 <p>R166G-B Triangular Positive Page H.11 7°</p>	 <p>L166L-ISO Triangular Positive Page H.11 7°</p>	 <p>R166L-ISO Triangular Positive Page H.11 7°</p>		
--	--	--	--	---	--	--

Partial profile thread forms - External inserts
60° - 55° (non topping)

Normally available for immediate delivery ●

Only available in a limited quantity ○

Inserts

General turning

Aluminium
wheel turning

Automatic lathes

Ceramic tools

Parting and
grooving

Threading



ER



ER TD

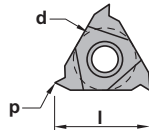

ER

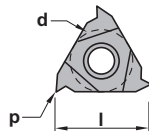

EL

ER-60°

	l	d	p	KM15	PM25	TIN25	TL20
11ER-A60	11,00	6,35	60°			○	
16ER-A60	16,00	9,52	60°			○	
16ER-AG60	16,00	9,52	60°		●	●	○
16ER-G60	16,00	9,52	60°			●	○
22ER-N60	22,00	12,70	60°			●	○
27ER-S60	27,00	15,87	60°			○	

EL-60°

	l	d	p	KM15	PM25	TIN25	TL20
11EL-A60	11,00	6,35	60°			○	
16EL-A60	16,00	9,52	60°			○	
16EL-AG60	16,00	9,52	60°			○	
16EL-G60	16,00	9,52	60°			○	
22EL-N60	22,00	12,70	60°			○	
27EL-S60	27,00	15,87	60°			○	

ER-55°

	l	d	p	KM15	PM25	TIN25	TL20
11ER-A55	11,00	6,35	55°			○	
16ER-A55	16,00	9,52	55°			○	
16ER-AG55	16,00	9,52	55°		●	●	○
16ER-G55	16,00	9,52	55°			○	
22ER-N55	22,00	12,70	55°			○	
27ER-S55	27,00	15,87	55°			○	

EL-55°

	l	d	p	KM15	PM25	TIN25	TL20
11EL-A55	11,00	6,35	55°			○	
16EL-A55	16,00	9,52	55°			○	
16EL-AG55	16,00	9,52	55°			○	
16EL-G55	16,00	9,52	55°			○	
22EL-N55	22,00	12,70	55°			○	
27EL-S55	27,00	15,87	55°			○	

ER-60° TD

	l	d	p	KM15	PM25	TIN25	TL20
16ER-A60 TD	16,00	9,52	60°			○	
16ER-AG60 TD	16,00	9,52	60°			●	○
16ER-G60 TD	16,00	9,52	60°			○	

ER-55° TD

	l	d	p	KM15	PM25	TIN25	TL20
16ER-A55TD	16,00	9,52	55°			○	
16ER-AG55 TD	16,00	9,52	55°			●	○
16ER-G55 TD	16,00	9,52	55°			○	

Partial profile thread forms - Internal inserts
60° - 55° (non topping)

Normally available for immediate delivery ●

Only available in a limited quantity ○



NR



NR TD

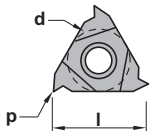

NR

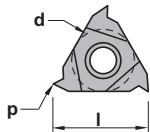

NL

NR-60°

	l	d	p	KM15	PM25	TIN25	TL20
06NR-A60	6,00	3,96	60°			○	
08NR-A60	8,00	4,76	60°			○	
11NR-A60	11,00	6,35	60°			●	○
16NR-A60	16,00	9,52	60°			○	
16NR-AG60	16,00	9,52	60°		●	●	○
16NR-G60	16,00	9,52	60°			○	
22NR-N60	22,00	12,70	60°			●	○
27NR-S60	27,00	15,87	60°			○	

NL-60°

	l	d	p	KM15	PM25	TIN25	TL20
06NL-A60	6,00	3,96	60°			○	
08NL-A60	8,00	4,76	60°			○	
11NL-A60	11,00	6,35	60°			○	
16NL-A60	16,00	9,52	60°			○	
16NL-AG60	16,00	9,52	60°			○	
16NL-G60	16,00	9,52	60°			○	
22NL-N60	22,00	12,70	60°			○	
27NL-S60	27,00	15,87	60°			○	

NR-55°

	l	d	p	KM15	PM25	TIN25	TL20
06NR-A55	6,00	3,96	55°			○	
08NR-A55	8,00	4,76	55°			○	
11NR-A55	11,00	6,35	55°			○	
16NR-A55	16,00	9,52	55°			○	
16NR-AG55	16,00	9,52	55°			●	○
16NR-G55	16,00	9,52	55°			●	
22NR-N55	22,00	12,70	55°			○	
27NR-S55	27,00	15,87	55°			○	

NL-55°

	l	d	p	KM15	PM25	TIN25	TL20
06NL-A55	6,00	3,96	55°				
08NL-A55	8,00	4,76	55°				
11NL-A55	11,00	6,35	55°			○	
16NL-A55	16,00	9,52	55°			○	
16NL-AG55	16,00	9,52	55°			○	
16NL-G55	16,00	9,52	55°			○	
22NL-N55	22,00	12,70	55°			○	
27NL-S55	27,00	15,87	55°				

NR-60° TD

	l	d	p	KM15	PM25	TIN25	TL20
16NR-A60 TD	16,00	9,52	60°			○	
16NR-AG60 TD	16,00	9,52	60°			●	○
16NR-G60 TD	16,00	9,52	60°			○	

NR-55° TD

	l	d	p	KM15	PM25	TIN25	TL20
16NR-A55TD	16,00	9,52	55°			○	
16NR-AG55 TD	16,00	9,52	55°			●	○
16NR-G55 TD	16,00	9,52	55°			○	

Mechanical thread forms - External inserts
ISO (full form) BS36

Normally available for immediate delivery ●

Only available in a limited quantity ○

Inserts

General turning

Aluminium wheel turning

Automatic lathes

Ceramic tools

Parting and grooving

Threading

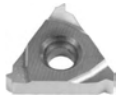

ER ISO



ER ISO TD

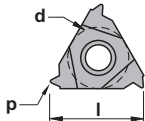

ER

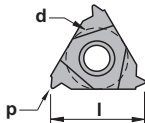

EL

ER-ISO

	l	d	p	KM15	PM25	TIN25	TL20
11ER-030ISO	11,00	6,35	0,30			○	
11ER-040ISO	11,00	6,35	0,40			○	
11ER-045ISO	11,00	6,35	0,45			○	
11ER-050ISO	11,00	6,35	0,50			○	
11ER-060ISO	11,00	6,35	0,60			○	
11ER-070ISO	11,00	6,35	0,70			○	
11ER-075ISO	11,00	6,35	0,75			○	
11ER-080ISO	11,00	6,35	0,80			○	
11ER-100ISO	11,00	6,35	1,00			○	
11ER-125ISO	11,00	6,35	1,25			○	
11ER-150ISO	11,00	6,35	1,50			○	
11ER-175ISO	11,00	6,35	1,75			○	
16ER-075ISO	16,00	9,52	0,75			○	
16ER-100ISO	16,00	9,52	1,00			○	
16ER-125ISO	16,00	9,52	1,25			○	
16ER-150ISO	16,00	9,52	1,50			○	
16ER-175ISO	16,00	9,52	1,75			○	
16ER-200ISO	16,00	9,52	2,00			○	
16ER-250ISO	16,00	9,52	2,50			○	
16ER-300ISO	16,00	9,52	3,00			○	
22ER-350ISO	22,00	12,70	3,50			○	
22ER-400ISO	22,00	12,70	4,00			○	
22ER-450ISO	22,00	12,70	4,50			○	
22ER-500ISO	22,00	12,70	5,00			○	
27ER-500ISO	27,00	15,87	5,00			○	
27ER-550ISO	27,00	15,87	5,50			○	
27ER-600ISO	27,00	15,87	6,00			○	
27ER-800ISO	27,00	15,87	8,00			○	

EL-ISO

	l	d	p	KM15	PM25	TIN25	TL20
16EL-100ISO	16,00	9,52	1,00			○	
16EL-125ISO	16,00	9,52	1,25			○	
16EL-150ISO	16,00	9,52	1,50			○	
16EL-175ISO	16,00	9,52	1,75			○	
16EL-200ISO	16,00	9,52	2,00			○	
16EL-250ISO	16,00	9,52	2,50			○	
16EL-300ISO	16,00	9,52	3,00			○	
22EL-400ISO	22,00	12,70	4,00			○	

ER-ISO TD

	l	d	p	KM15	PM25	TIN25	TL20
16ER-100ISO TD	16,50	9,52	1,00			○	
16ER-125ISO TD	16,50	9,52	1,25			○	
16ER-150ISO TD	16,50	9,52	1,50			○	
16ER-175ISO TD	16,50	9,52	1,75			○	
16ER-200ISO TD	16,50	9,52	2,00			○	
16ER-250ISO TD	16,50	9,52	2,50			○	
16ER-300ISO TD	16,50	9,52	3,00			○	

EL-ISO TD

	l	d	p	KM15	PM25	TIN25	TL20
16EL-100ISO TD	16,50	9,52	1,00			○	
16EL-125ISO TD	16,50	9,52	1,25			○	
16EL-150ISO TD	16,50	9,52	1,50			○	
16EL-175ISO TD	16,50	9,52	1,75			○	
16EL-200ISO TD	16,50	9,52	2,00			○	
16EL-250ISO TD	16,50	9,52	2,50			○	
16EL-300ISO TD	16,50	9,52	3,00			○	

Mechanical thread forms - Internal inserts
ISO (full form) BS36

Normally available for immediate delivery ●

Only available in a limited quantity ○

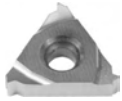

NR ISO



NR ISO TD

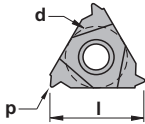

NR

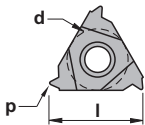

NL

NR-ISO

	l	d	p	KM15	PM25	TIN25	TL20
06NR-050ISO	6,00	3,96	0,50			○	
06NR-075ISO	6,00	3,96	0,75			○	
06NR-100ISO	6,00	3,96	1,00			○	
06NR-125ISO	6,00	3,96	1,25			○	
08NR-050ISO	8,00	4,76	0,50			○	
08NR-075ISO	8,00	4,76	0,75			○	
08NR-100ISO	8,00	4,76	1,00			○	
08NR-125ISO	8,00	4,76	1,25			○	
08NR-150ISO	8,00	4,76	1,50			○	
08NR-175ISO	8,00	4,76	1,75			○	
11NR-035ISO	11,00	6,35	0,35			○	
11NR-040ISO	11,00	6,35	0,40			○	
11NR-045ISO	11,00	6,35	0,45			○	
11NR-050ISO	11,00	6,35	0,50			○	
11NR-060ISO	11,00	6,35	0,60			○	
11NR-070ISO	11,00	6,35	0,70			○	
11NR-075ISO	11,00	6,35	0,75			○	
11NR-080ISO	11,00	6,35	0,80			○	
11NR-100ISO	11,00	6,35	1,00			○	
11NR-125ISO	11,00	6,35	1,25			○	
11NR-150ISO	11,00	6,35	1,50			○	
11NR-175ISO	11,00	6,35	1,75			○	
11NR-200ISO	11,00	6,35	2,00			○	
11NR-250ISO	11,00	6,35	2,50			○	
16NR-075ISO	16,00	9,52	0,75			○	
16NR-100ISO	16,00	9,52	1,00			○	
16NR-125ISO	16,00	9,52	1,25			○	
16NR-150ISO	16,00	9,52	1,50			○	
16NR-175ISO	16,00	9,52	1,75			○	
16NR-200ISO	16,00	9,52	2,00			○	
16NR-250ISO	16,00	9,52	2,50			○	
16NR-300ISO	16,00	9,52	3,00			○	
22NR-350ISO	22,00	12,70	3,50			○	
22NR-400ISO	22,00	12,70	4,00			○	
22NR-450ISO	22,00	12,70	4,50			○	
22NR-500ISO	22,00	12,70	5,00			○	
27NR-500ISO	27,00	15,87	5,00			○	
27NR-550ISO	27,00	15,87	5,50			○	
27NR-600ISO	27,00	15,87	6,00			○	
27NR-800ISO	27,00	15,87	8,00			○	

NL-ISO

	l	d	p	KM15	PM25	TIN25	TL20
06NL-050ISO	6,00	3,96	0,50			○	
06NL-075ISO	6,00	3,96	0,75			○	
06NL-100ISO	6,00	3,96	1,00			○	
06NL-125ISO	6,00	3,96	1,25			○	
08NL-050ISO	8,00	4,76	0,50			○	
08NL-075ISO	8,00	4,76	0,75			○	
08NL-100ISO	8,00	4,76	1,00			○	
08NL-125ISO	8,00	4,76	1,25			○	
08NL-150ISO	8,00	4,76	1,50			○	
08NL-175ISO	8,00	4,76	1,75			○	
11NL-100ISO	11,00	6,35	1,00			○	
11NL-150ISO	11,00	6,35	1,50			○	
16NL-100ISO	16,00	9,52	1,00			○	
16NL-125ISO	16,00	9,52	1,25			○	
16NL-150ISO	16,00	9,52	1,50			○	
16NL-175ISO	16,00	9,52	1,75			○	
16NL-200ISO	16,00	9,52	2,00			○	
16NL-250ISO	16,00	9,52	2,50			○	
16NL-300ISO	16,00	9,52	3,00			○	
22NL-400ISO	22,00	12,70	4,00			○	

NR-ISO TD

	l	d	p	KM15	PM25	TIN25	TL20
16NR-100ISO TD	16,50	9,52	1,00			●	
16NR-125ISO TD	16,50	9,52	1,25			●	
16NR-150ISO TD	16,50	9,52	1,50			●	
16NR-175ISO TD	16,50	9,52	1,75			●	
16NR-200ISO TD	16,50	9,52	2,00			●	
16NR-250ISO TD	16,50	9,52	2,50			●	
16NR-300ISO TD	16,50	9,52	3,00			●	

Mechanical thread forms - External and internal inserts
UNIFIED (full form) ASME/ANSI B1.1

Normally available for immediate delivery ●

Only available in a limited quantity ○

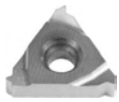

ER UN

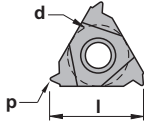

ER

ER-UN

	l	d	p	KM15	PM25	TIN25	TL20
16ER-11UN	16,00	9,52	11,0			○	
16ER-14UN	16,00	9,52	14,0			○	
16ER-18UN	16,00	9,52	18,0			○	

NR-UN

	l	d	p	KM15	PM25	TIN25	TL20
16NR-20UN	16,00	9,52	20,0			○	
16NR-24UN	16,00	9,52	24,0			○	

Mechanical thread forms - External and internal inserts
WHITWORTH (full form) BS84

Normally available for immediate delivery ●

Only available in a limited quantity ○



ER-W



ER-W TD

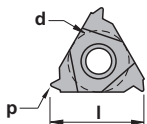

ER

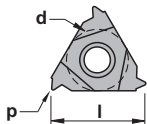

EL

ER-W

	l	d	p	KM15	PM25	TIN25	TL20
11ER-14W	11,00	6,35	14,0			○	
11ER-16W	11,00	6,35	16,0			○	
11ER-18W	11,00	6,35	18,0			○	
11ER-19W	11,00	6,35	19,0			○	
11ER-22W	11,00	6,35	22,0			○	
11ER-24W	11,00	6,35	24,0			○	
11ER-26W	11,00	6,35	26,0			○	
11ER-28W	11,00	6,35	28,0			○	
11ER-40W	11,00	6,35	40,0			○	
11ER-50W	11,00	6,35	50,0			○	
11ER-56W	11,00	6,35	56,0			○	
16ER-8W	16,00	9,52	8,0			○	
16ER-9W	16,00	9,52	9,0			○	
16ER-10W	16,00	9,52	10,0			○	
16ER-11W	16,00	9,52	11,0			○	
16ER-12W	16,00	9,52	12,0			○	
16ER-14W	16,00	9,52	14,0			○	
16ER-16W	16,00	9,52	16,0			○	
16ER-18W	16,00	9,52	18,0			○	
16ER-19W	16,00	9,52	19,0			○	
16ER-20W	16,00	9,52	20,0			○	
16ER-22W	16,00	9,52	22,0			○	
16ER-24W	16,00	9,52	24,0			○	
16ER-26W	16,00	9,52	26,0			○	
16ER-28W	16,00	9,52	28,0			○	
22ER-4W	22,00	12,70	4,0			○	
22ER-4.5W	22,00	12,70	4,5			○	
22ER-5W	22,00	12,70	5,0			○	
22ER-6W	22,00	12,70	6,0			○	
22ER-7W	22,00	12,70	7,0			○	
22ER-8W	22,00	12,70	8,0			○	
27ER-4W	27,00	15,87	4,0			○	
27ER-4.5W	27,00	15,87	4,5			○	

EL-W

	l	d	p	KM15	PM25	TIN25	TL20
16EL-11W	16,00	9,52	11,0			○	
16EL-14W	16,00	9,52	14,0			○	
16EL-20W	16,00	9,52	20,0			○	

ER-W TD

	l	d	p	KM15	PM25	TIN25	TL20
16ER-11W TD	16,50	9,52	11,0			○	
16ER-14W TD	16,50	9,52	14,0			○	
16ER-16W TD	16,50	9,52	16,0			○	

Inserts

General turning

Aluminium wheel turning

Automatic lathes

Ceramic tools

Parting and grooving

Threading

Mechanical thread forms - Internal inserts
WHITWORTH (full form) BS84

Normally available for immediate delivery ●

Only available in a limited quantity ○



NR-W



NR-W TD

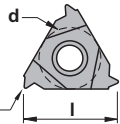

NR

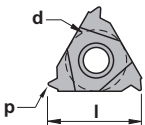

NL

NR-W

	l	d	p	KM15	PM25	TIN25	TL20
06NR-18W	6,00	3,96	18,0			○	
06NR-19W	6,00	3,96	19,0			○	
06NR-20W	6,00	3,96	20,0			○	
06NR-22W	6,00	3,96	22,0			○	
06NR-26W	6,00	3,96	26,0			○	
08NR-16W	8,00	4,76	16,0			○	
08NR-18W	8,00	4,76	18,0			○	
08NR-19W	8,00	4,76	19,0			○	
08NR-20W	8,00	4,76	20,0			○	
08NR-24W	8,00	4,76	24,0			○	
08NR-28W	8,00	4,76	28,0			○	
11NR-11W	11,00	6,35	11,0			○	
11NR-12W	11,00	6,35	12,0			○	
11NR-14W	11,00	6,35	14,0			○	
11NR-16W	11,00	6,35	16,0			○	
11NR-18W	11,00	6,35	18,0			○	
11NR-19W	11,00	6,35	19,0			○	
11NR-20W	11,00	6,35	20,0			○	
11NR-22W	11,00	6,35	22,0			○	
11NR-24W	11,00	6,35	24,0			○	
11NR-26W	11,00	6,35	26,0			○	
11NR-28W	11,00	6,35	28,0			○	
11NR-32W	11,00	6,35	32,0			○	
11NR-36W	11,00	6,35	36,0			○	
11NR-40W	11,00	6,35	40,0			○	
11NR-48W	11,00	6,35	48,0			○	
16NR-8W	16,00	9,52	8,0			○	
16NR-9W	16,00	9,52	9,0			○	
16NR-10W	16,00	9,52	10,0			○	
16NR-11W	16,00	9,52	11,0			○	
16NR-12W	16,00	9,52	12,0			○	
16NR-14W	16,00	9,52	14,0			○	
16NR-16W	16,00	9,52	16,0			○	
16NR-18W	16,00	9,52	18,0			○	
16NR-19W	16,00	9,52	19,0			○	
16NR-20W	16,00	9,52	20,0			○	
16NR-22W	16,00	9,52	22,0			○	
16NR-24W	16,00	9,52	24,0			○	
16NR-26W	16,00	9,52	26,0			○	
16NR-28W	16,00	9,52	28,0			○	
22NR-4W	22,00	12,70	4,0			○	
22NR-4.5W	22,00	12,70	4,5			○	
22NR-5W	22,00	12,70	5,0			○	
22NR-6W	22,00	12,70	6,0			○	
22NR-7W	22,00	12,70	7,0			○	

NL-W

	l	d	p	KM15	PM25	TIN25	TL20
06NL-18W	6,00	3,96	18,0			○	
06NL-20W	6,00	3,96	20,0			○	
06NL-22W	6,00	3,96	22,0			○	
06NL-26W	6,00	3,96	26,0			○	
08NL-16W	8,00	4,76	16,0			○	
08NL-18W	8,00	4,76	18,0			○	
08NL-19W	8,00	4,76	19,0			○	
08NL-20W	8,00	4,76	20,0			○	
08NL-24W	8,00	4,76	24,0			○	
08NL-28W	8,00	4,76	28,0			○	
16NL-11W	16,00	9,52	11,0			○	
16NL-14W	16,00	9,52	14,0			○	
16NL-16W	16,00	9,52	16,0			○	
16NL-20W	16,00	9,52	20,0			○	

NR-W TD

	l	d	p	KM15	PM25	TIN25	TL20
16NR-8W TD	16,50	9,52	8,0			○	
16NR-9W TD	16,50	9,52	9,0			○	
16NR-10W TD	16,50	9,52	10,0			○	
16NR-11W TD	16,50	9,52	11,0			●	○
16NR-12W TD	16,50	9,52	12,0			○	
16NR-14W TD	16,50	9,52	14,0			●	○
16NR-16W TD	16,50	9,52	16,0			○	
16NR-18W TD	16,50	9,52	18,0			○	
16NR-19W TD	16,50	9,52	19,0			○	

- Inserts
- General turning
- Aluminium wheel turning
- Automatic lathes
- Ceramic tools
- Parting and grooving
- Threading

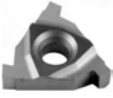
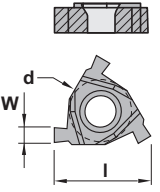
Grooving - External inserts		Normally available for immediate delivery ● Only available in a limited quantity ○							
Lock ring groove inserts type LG									
 ER-LG	ER-LG		l	d	W	KM15	PM25	TIN25	TL20
	16ER-100LG		16,00	9,52	1,15				●
	16ER-120LG		16,00	9,52	1,35				●
	16ER-150LG		16,00	9,52	1,65				●
	16ER-175LG		16,00	9,52	1,90				●
	16ER-200LG		16,00	9,52	2,15				●
	16ER-250LG		16,00	9,52	2,65				●
 EL-LG	EL-LG		l	d	W	KM15	PM25	TIN25	TL20
	16EL-100LG		16,00	9,52	1,15				●
	16EL-120LG		16,00	9,52	1,35				●
	16EL-150LG		16,00	9,52	1,65				●
	16EL-175LG		16,00	9,52	1,90				●
	16EL-200LG		16,00	9,52	2,15				●

Negative triangular insert for threading.		Normally available for immediate delivery ● Only available in a limited quantity ○							
 TNMC	TNMC		l	s	d	KM15	PM25	TIN16	TL20
	TNMC 1603XX		16,50	3,18	9,52		○	○	●
	TNMC 2204XX		22,00	4,76	12,70		●	○	●

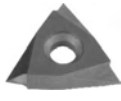
Negative triangular insert for threading.		Normally available for immediate delivery ● Only available in a limited quantity ○							
 TPMC	TPMC		l	s	d	KM15	PM25	TIN16	TL20
	TPMC 1603XX		16,50	3,18	9,52		○	○	●
	TPMC 2204XX		22,00	4,76	12,70		○	○	●

Positive 7° clearance - Triangular insert for threading. Normally available for immediate delivery ●
Only available in a limited quantity ○

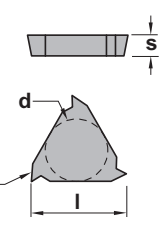

L166G-ISO

	l	s	d	p	KM15	PM25	TIN25	TL20
	L166G-3BA075	16,50	3,18	9,52	0,75	○		
	L166G-3BA100	16,50	3,18	9,52	1,00	○		
	L166G-3BA125	16,50	3,18	9,52	1,25	○		
	L166G-3BA150	16,50	3,18	9,52	1,50	○		
	L166G-3BA175	16,50	3,18	9,52	1,75	○		
	L166G-3BA200	16,50	3,18	9,52	2,00	○		
	L166G-3BA250	16,50	3,18	9,52	2,50	○		
	L166G-3BA300	16,50	3,18	9,52	3,00	○		

Positive 7° clearance - Triangular insert for threading. Normally available for immediate delivery ●
Only available in a limited quantity ○

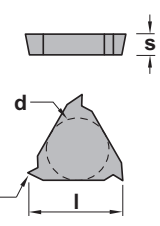

R166G-ISO

	l	s	d	p	KM15	PM25	TIN25	TL20
	R166G-3BA075	16,50	3,18	9,52	0,75	○		
	R166G-3BA100	16,50	3,18	9,52	1,00	○		
	R166G-3BA125	16,50	3,18	9,52	1,25	○		
	R166G-3BA150	16,50	3,18	9,52	1,50	○		
	R166G-3BA175	16,50	3,18	9,52	1,75	○		
	R166G-3BA200	16,50	3,18	9,52	2,00	○		
	R166G-3BA250	16,50	3,18	9,52	2,50	○		
	R166G-3BA300	16,50	3,18	9,52	3,00	○		

Positive 7° clearance - Triangular insert for threading. Normally available for immediate delivery ●
Only available in a limited quantity ○

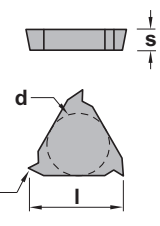

R166G-B

	l	s	d	p	KM15	PM25	TIN25	TL20
	R166G-3BK080	16,50	3,18	9,52	08	○		
	R166G-3BK160	16,50	3,18	9,52	16	○		
	R166G-3BL110	16,50	3,18	9,52	11	○		
	R166G-3BL160	16,50	3,18	9,52	16	○		

Positive 7° clearance - Triangular insert for threading. Normally available for immediate delivery ●
Only available in a limited quantity ○

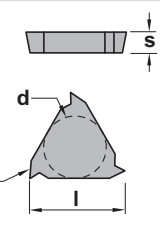

L166L-ISO

	l	s	d	p	KM15	PM25	TIN25	TL20
	L166L-3BA150	16,50	3,18	9,52	1,50	○		
	L166L-3BA175	16,50	3,18	9,52	1,75	○		
	L166L-3BA200	16,50	3,18	9,52	2,00	○		
	L166L-3BA250	16,50	3,18	9,52	2,50	○		
	L166L-3BA300	16,50	3,18	9,52	3,00	○		

Positive 7° clearance - Triangular insert for threading. Normally available for immediate delivery ●
Only available in a limited quantity ○



R166L-ISO

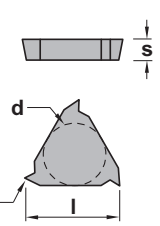





	l	s	d	p	KM15	PM25	TIN25	TL20
	R166L-2BA100	11,00	3,18	6,35	1,00	○		
	R166L-2BA150	11,00	3,18	6,35	1,50	○		
	R166L-3BA150	16,50	3,18	9,52	1,50	○		
	R166L-3BA175	16,50	3,18	9,52	1,75	○		
	R166L-3BA200	16,50	3,18	9,52	2,00	○		
	R166L-3BA250	16,50	3,18	9,52	2,50	○		
	R166L-3BA300	16,50	3,18	9,52	3,00	○		
	R166L-3BK080	16,50	3,18	9,52	08	○		

- Inserts
- General turning
- Aluminium wheel turning
- Automatic lathes
- Ceramic tools
- Parting and grooving
- Threading

External threading

<p>SXAN 90°</p>  <p>08 ER/L.. 11 ER/L.. 16 ER/L.. 22 ER/L..</p> <p>Page H.13</p>	<p>STAN 90°</p>  <p>16 ER/L.. 22 ER/L.. 27 ER/L..</p> <p>Page H.14</p>	<p>CTAN 90°</p>  <p>16 ER/L.. 22 ER/L.. 27 ER/L..</p> <p>Page H.15</p>	<p>SXGN 90°</p>  <p>Page H.16</p> <p>R/L 166G-3.. R/L 166G-4..</p>	<p>STXN 90°</p>  <p>Page H.17</p> <p>16 ER/L.. 22 ER/L.. 27 ER/L..</p>	<p>CTXN 90°</p>  <p>Page H.18</p> <p>16 ER/L.. 22 ER/L.. 27 ER/L..</p>
<p>STCN 90°</p>  <p>Page H.19</p> <p>TNMC 1603.. TPMC 1603.. TNMC 2204.. TPMC 2204..</p>	<p>CXAP 90°</p>  <p>Page H.20</p> <p>R/L 166-3.. R/L 166-4..</p>				

Internal threading

<p>SXFN 90°</p>  <p>Page H.21</p> <p>11 NR/L.. 22 NR/L..</p>	<p>STXN 90°</p>  <p>Page H.23</p> <p>11 NR/L.. 16 NR/L.. 22 NR/L.. 27 NR/L..</p>	<p>CTXN 90°</p>  <p>Page H.24</p> <p>16 NR/L.. 22 NR/L.. 27 NR/L..</p>	<p>STGN 90°</p>  <p>Page H.25</p> <p>TNMC 1603.. TNMC 2204..</p>	<p>STGP 90°</p>  <p>Page H.26</p> <p>TPMC 1603.. TPMC 2204..</p>	<p>CXFP 90°</p>  <p>Page H.27</p> <p>R/L 166-2.. R/L 166-3.. R/L 166-4..</p>
---	---	---	--	---	---

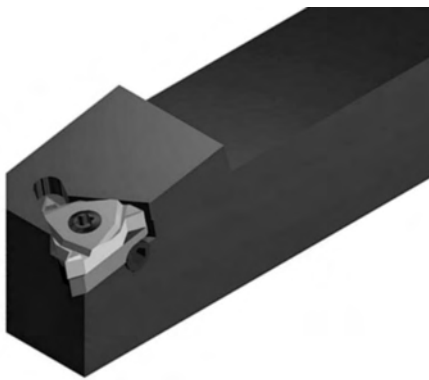

Characteristics:

Threading toolholder for negative lay down inserts.
The screw clamping ensures a good stiffness and evacuation of chips.
The insert is positioned a -10° cutting angle, and a -1° clearance angle.

Applications:

Multipurpose threading toolholders.

Metric screws

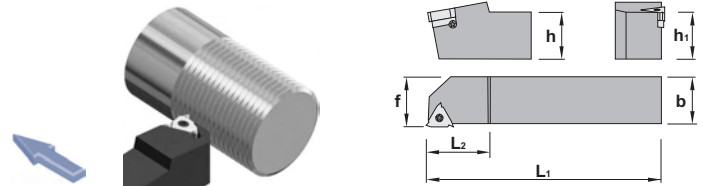

SXAN 90°

Ref.		h=h ₁	b	L ₁	L ₂	f	Insert size	Kg
SXAN R/L 0808 M08		8	8	150	20	8	08 ER/L..	0,070
	SXAN R/L 1010 M08	10	10	150	20	10	08 ER/L..	0,100
SXAN R/L 1212 M11		12	12	150	20	12	11 ER/L..	0,140
SXAN R/L 1616 H16		16	16	100	22	16	16 ER/L..	0,200
SXAN R/L 1616 M16		16	16	150	22	16	16 ER/L..	0,270
SXAN R/L 2020 K16		20	20	125	28	20	16 ER/L..	0,400
SXAN R/L 2525 M16		25	25	150	28	25	16 ER/L..	0,700
SXAN R/L 3232 P16		32	32	170	28	32	16 ER/L..	1,300
SXAN R/L 2525 M22		25	25	150	34	25	22 ER/L..	0,700
SXAN R/L 3232 P22		32	32	170	34	32	22 ER/L..	1,300

Ref.					
SXAN R/L 0808 M08	1225	5507	-	-	-
SXAN R/L 1010 M08	1225	5507	-	-	-
SXAN R/L 1212 M11	1225	5507	-	-	-
SXAN R/L 1616 H16	1335	5515	3424	3425	1093
SXAN R/L 1616 M16	1335	5515	3424	3425	1093
SXAN R/L 2020 K16	1335	5515	3424	3425	1093
SXAN R/L 2525 M16	1335	5515	3424	3425	1093
SXAN R/L 3232 P16	1335	5515	3424	3425	1093
SXAN R/L 2525 M22	1340	5515	3430	3431	1094
SXAN R/L 3232 P22	1340	5515	3430	3431	1094

Ref.	E R/L		I	d	Negative triangular inserts for external threading
	08 ER/L		8,00	4,76	
11 ER/L		11,00	6,35		
16 ER/L..		16,00	9,52		
22 ER/L..		22,00	12,70		

ER/L	ER/L TD				

For more information see page: H.04

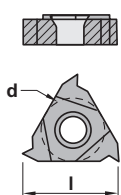

Inserts

General turning

Aluminium wheel turning

Automatic lathes

Ceramic tools

Parting and grooving

Threading

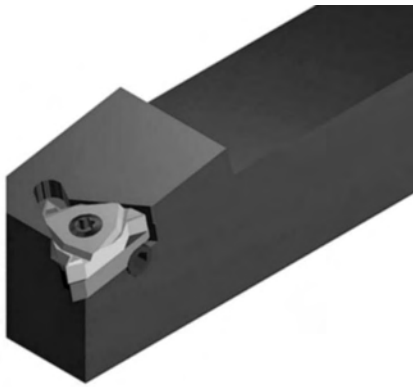

Characteristics:

Threading toolholder for negative lay down inserts.
The screw clamping ensures a good stiffness and evacuation of chips.
The insert is positioned a -10° cutting angle, and a -1° clearance angle.

Applications:

Multipurpose threading toolholders.

Whitworth screws

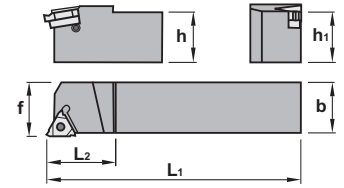
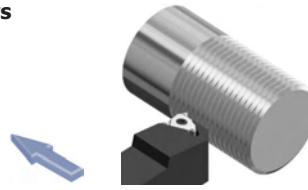

STAN 90°

Ref.		h=h ₁	b	L ₁	L ₂	f	Insert size	Kg
STAN R/L	1616 H16	16	16	100	20,5	16	16 ER/L..	0,200
	2020 K16	20	20	125	30,0	20	16 ER/L..	0,400
	2525 M16	25	25	150	30,0	25	16 ER/L..	0,700
	3232 P16	32	32	170	30,0	32	16 ER/L..	1,300
	2525 M22	25	25	150	36,0	25	22 ER/L..	0,700
	3232 P22	32	32	175	36,0	32	22 ER/L..	1,300
	4040 R22	40	40	200	36,0	40	22 ER/L..	3,000
	3232 P27	32	32	170	40,0	32	27 ER/L..	1,300
	4040 R27	40	40	200	40,0	40	27 ER/L..	3,000
	5050 S27	50	50	250	40,0	50	27 ER/L..	5,800

Ref.					
STAN R/L 1616 H16	SA3	5510	YE3	Y13	SY3
STAN R/L 2020 K16	SA3	5510	YE3	Y13	SY3
STAN R/L 2525 M16	SA3	5510	YE3	Y13	SY3
STAN R/L 3232 P16	SA3	5510	YE3	Y13	SY3
STAN R/L 2525 M22	SA4	5520	YE4	Y14	SY4
STAN R/L 3232 P22	SA4	5520	YE4	Y14	SY4
STAN R/L 4040 R22	SA4	5520	YE4	Y14	SY4
STAN R/L 3232 P27	SA5	5525	YE5	Y15	SY5
STAN R/L 4040 R27	SA5	5525	YE5	Y15	SY5
STAN R/L 5050 S27	SA5	5525	YE5	Y15	SY5

Ref.	E R/L		I	d	Negative triangular inserts for external threading
	16 ER/L..		16,00	9,52	
22 ER/L..		22,00	12,70		
27 ER/L..		27,50	15,88		
	ER/L	ER/L TD			

For more information see page: H.04

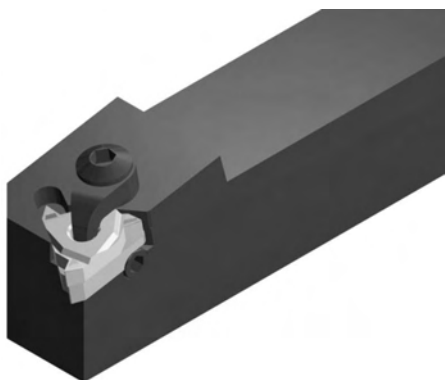

Characteristics:

Top clamp threading toolholder for negative lay down inserts.
The insert is positioned a -10° cutting angle, and a -1° clearance angle.

Applications:

Multipurpose threading toolholders.

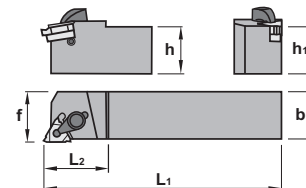
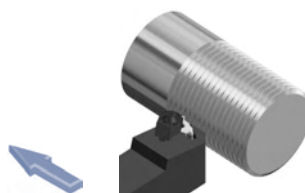

CTAN 90°

Ref.		h=h ₁	b	L ₁	L ₂	f	Insert size	Kg
CTAN R/L 2020 K16	CTAN R/L 2020 K16	20	20	125	30	20	16 ER/L..	0,400
	CTAN R/L 2525 M16	25	25	150	30	25	16 ER/L..	0,700
	CTAN R/L 3232 P16	32	32	170	30	32	16 ER/L..	1,050
CTAN R/L 2525 M22	CTAN R/L 2525 M22	25	25	150	36	25	22 ER/L..	0,700
	CTAN R/L 3232 P22	32	32	170	36	32	22 ER/L..	1,300
	CTAN R/L 4040 R22	40	40	200	36	40	22 ER/L..	3,000
CTAN R/L 3232 P27	CTAN R/L 3232 P27	32	32	170	40	32	27 ER/L..	1,300
	CTAN R/L 4040 R27	40	40	200	40	40	27 ER/L..	3,000
	CTAN R/L 5050 S27	50	50	250	40	50	27 ER/L..	5,800

Ref.									
CTAN R/L 2020 K16	2516	5515	YE3	Y13	SY3	SA3			
CTAN R/L 2525 M16	2516	5515	YE3	Y13	SY3	SA3			
CTAN R/L 3232 P16	2516	5515	YE3	Y13	SY3	SA3			
CTAN R/L 2525 M22	2522	5515	YE4	Y14	SY4	SA4			
CTAN R/L 3232 P22	2522	5515	YE4	Y14	SY4	SA4			
CTAN R/L 4040 R22	2522	5515	YE4	Y14	SY4	SA4			
CTAN R/L 3232 P27	2527	5525	YE5	Y15	SY5	SA5			
CTAN R/L 4040 R27	2527	5525	YE5	Y15	SY5	SA5			
CTAN R/L 5050 S27	2527	5525	YE5	Y15	SY5	SA5			Optional

	E R/L		I	d	Negative triangular inserts for external threading For more information see page: H.04
	Ref.	16 ER/L..	16,00	9,52	
		22 ER/L..	22,00	12,70	
	27 ER/L..	27,50	15,88		
	ER/L	ER/L TD			

Threading
Drills
Cartridges
Brazed tools
Tooling

- Inserts
- General turning
- Aluminium wheel turning
- Automatic lathes
- Ceramic tools
- Parting and grooving
- Threading

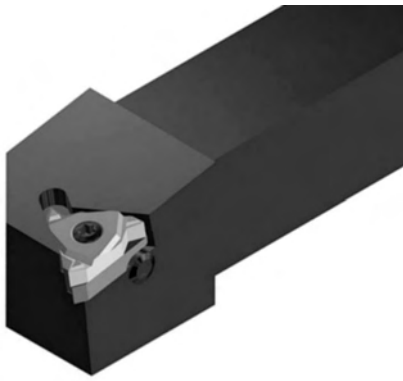

Characteristics:

Threading toolholder for negative lay down inserts.
The screw clamping ensures good stiffness and evacuation of chips.
The insert is positioned a -10° cutting angle, and a -1° clearance angle.





Applications:

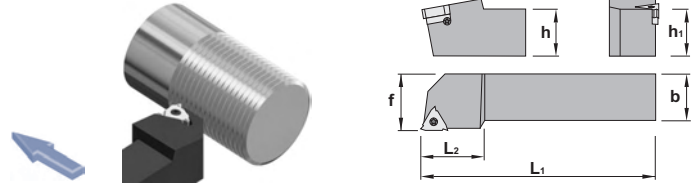

Multipurpose threading toolholders.

Metric screws



SXGN 90°		h=h₁	b	L₁	L₂	f	Insert size	kg
Ref.	SXGN R/L 1212 F16	12	12	80	22	16	16 ER/L..	0,100
	SXGN R/L 1616 H16	16	16	100	22	20	16 ER/L..	0,200
	SXGN R/L 2020 K16	20	20	125	28	25	16 ER/L..	0,400
	SXGN R/L 2525 M16	25	25	150	28	32	16 ER/L..	0,700
	SXGN R/L 3232 P16	32	32	170	28	40	16 ER/L..	1,050
	SXGN R/L 2525 M22	25	25	150	34	32	22 ER/L..	0,700
	SXGN R/L 3232 P22	32	32	170	34	40	22 ER/L..	1,050

Ref.			 R	 L	
SXGN R/L 1212 F16	1335	5515	3424	3425	1093
SXGN R/L 1616 H16	1335	5515	3424	3425	1093
SXGN R/L 2020 K16	1335	5515	3424	3425	1093
SXGN R/L 2525 M16	1335	5515	3424	3425	1093
SXGN R/L 3232 P16	1335	5515	3424	3425	1093
SXGN R/L 2525 M22	1340	5515	3430	3431	1094
SXGN R/L 3232 P22	1340	5515	3430	3431	1094

Ref.	E R/L		l	d	Negative triangular inserts for external threading
		16 ER/L..	22 ER/L..	16,00	
			22,00	12,70	
	ER/L	ER/L TD			
					

For more information see page: H.04

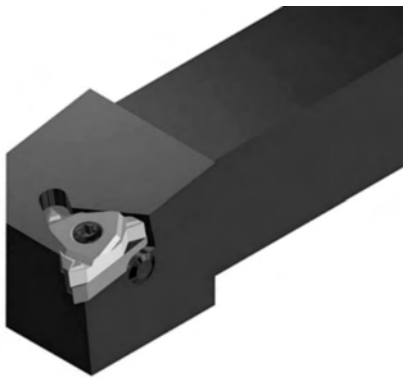

Characteristics:

Threading toolholder for negative lay down inserts.
The screw clamping ensures a good stiffness and evacuation of chips.
The insert is positioned a -10° cutting angle, and a -1° clearance angle.

Applications:

Multipurpose threading toolholders.

Whitworth screws

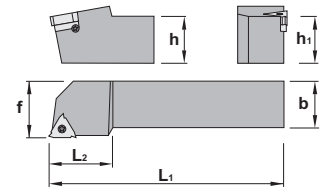
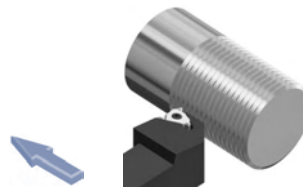

STXN 90°

Ref.		h=h ₁	b	L ₁	L ₂	f	Insert size	Kg
STXN R/L 1212 F16	STXN R/L 1212 F16	12	12	80	22,0	16	16 ER/L..	0,100
	STXN R/L 1616 H16	16	16	100	20,5	20	16 ER/L..	0,200
	STXN R/L 2020 K16	20	20	125	30,0	25	16 ER/L..	0,400
	STXN R/L 2525 M16	25	25	150	30,0	32	16 ER/L..	0,700
	STXN R/L 3232 P16	32	32	170	30,0	40	16 ER/L..	1,050
	STXN R/L 2525 M22	25	25	150	36,0	32	22 ER/L..	0,700
	STXN R/L 3232 P22	32	32	170	36,0	40	22 ER/L..	1,300
	STXN R/L 4040 R22	40	40	200	36,0	50	22 ER/L..	3,000
	STXN R/L 2525 M27	25	25	150	35,0	32	27 ER/L..	0,700
	STXN R/L 3232 P27	32	32	170	40,0	40	27 ER/L..	1,300
STXN R/L 4040 R27	40	40	200	40,0	50	27 ER/L..	3,000	
STXN R/L 5050 S27	50	50	250	40,0	60	27 ER/L..	5,800	

Ref.					
STXN R/L 1212 F16	SA3	5510	YE3	YI3	SY3
STXN R/L 1616 H16	SA3	5510	YE3	YI3	SY3
STXN R/L 2020 K16	SA3	5510	YE3	YI3	SY3
STXN R/L 2525 M16	SA3	5510	YE3	YI3	SY3
STXN R/L 3232 P16	SA3	5510	YE3	YI3	SY3
STXN R/L 2525 M22	SA4	5520	YE4	YI4	SY4
STXN R/L 3232 P22	SA4	5520	YE4	YI4	SY4
STXN R/L 4040 R22	SA4	5520	YE4	YI4	SY4
STXN R/L 2525 M27	SA5	5525	YE5	YI5	SY5
STXN R/L 3232 P27	SA5	5525	YE5	YI5	SY5
STXN R/L 4040 R27	SA5	5525	YE5	YI5	SY5
STXN R/L 5050 S27	SA5	5525	YE5	YI5	SY5

	E R/L		l	d	Negative triangular inserts for external threading
	Ref.	16 ER/L..	16,00	9,52	
		22 ER/L..	22,00	12,70	
	27 ER/L..	27,50	15,88		
	ER/L	ER/L TD			

For more information see page: H.04

Inserts

General turning

Aluminium wheel turning

Automatic lathes

Ceramic tools

Parting and grooving

Threading

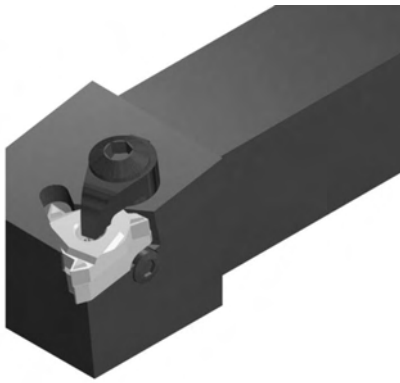

Characteristics:

Top clamp threading toolholder for negative lay down inserts.
The insert is positioned a -10° cutting angle, and a -1° clearance angle.

Applications:

Multipurpose threading toolholders.

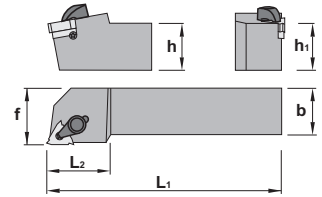
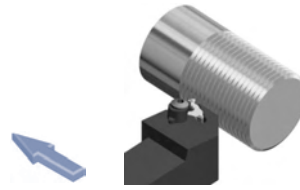

CTXN 90°

Ref.		h=h ₁	b	L ₁	L ₂	f	Insert size	Kg
Ref.	CTXN R/L 1212 F16	12	12	80	22,0	16	16 ER/L..	0,100
	CTXN R/L 1616 H16	16	16	100	20,5	20	16 ER/L..	0,200
	CTXN R/L 2020 K16	20	20	125	30,0	25	16 ER/L..	0,400
	CTXN R/L 2525 M16	25	25	150	30,0	32	16 ER/L..	0,700
	CTXN R/L 3232 P16	32	32	170	30,0	40	16 ER/L..	1,050
	CTXN R/L 2525 M22	25	25	150	36,0	32	22 ER/L..	0,700
	CTXN R/L 3232 P22	32	32	170	36,0	40	22 ER/L..	1,300
	CTXN R/L 4040 R22	40	40	200	36,0	50	22 ER/L..	3,000
	CTXN R/L 2525 M27	25	25	150	35,0	32	27 ER/L..	0,700
	CTXN R/L 3232 P27	32	32	170	40,0	40	27 ER/L..	1,300
CTXN R/L 4040 R27	40	40	200	40,0	50	27 ER/L..	3,000	
CTXN R/L 5050 S27	50	50	250	40,0	60	27 ER/L..	5,800	

Ref.												
Ref.	2516	5515	YE3	YI3	SY3	SA3						
CTXN R/L 1212 F16	2516	5515	YE3	YI3	SY3	SA3						
CTXN R/L 1616 H16	2516	5515	YE3	YI3	SY3	SA3						
CTXN R/L 2020 K16	2516	5515	YE3	YI3	SY3	SA3						
CTXN R/L 2525 M16	2516	5515	YE3	YI3	SY3	SA3						
CTXN R/L 3232 P16	2516	5515	YE3	YI3	SY3	SA3						
CTXN R/L 2525 M22	2522	5515	YE4	YI4	SY4	SA4						
CTXN R/L 3232 P22	2522	5515	YE4	YI4	SY4	SA4						
CTXN R/L 4040 R22	2522	5515	YE4	YI4	SY4	SA4						
CTXN R/L 2525 M27	2527	5525	YE5	YI5	SY5	SA5						
CTXN R/L 3232 P27	2527	5525	YE5	YI5	SY5	SA5						
CTXN R/L 4040 R27	2527	5525	YE5	YI5	SY5	SA5						
CTXN R/L 5050 S27	2527	5525	YE5	YI5	SY5	SA5						

Optional

Ref.	E R/L		I	d	Negative triangular inserts for external threading
	16 ER/L..		16,00	9,52	
22 ER/L..		22,00	12,70		
27 ER/L..		27,50	15,88		
					For more information see page: H.04
	ER/L	ER/L TD			



Characteristics:

Vertical on edge threading toolholder.
The insert is positioned with a 0° cutting angle, and a 0° clearance angle.

Applications:

Toolholders for threading.

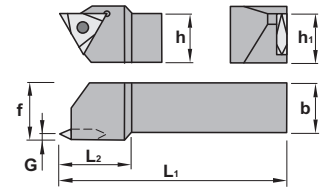
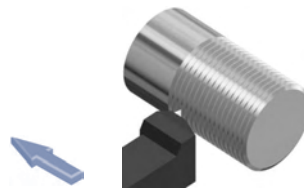

STCN 90°

Ref.		h=h ₁	b	L ₁	L ₂	f	G	Insert size	/kg
Ref.	STCN R/L 1212 F16	12	12	80	23	16	1,59	TNMC/TPMC 1603..	0,100
	STCN R/L 1616 H16	16	16	100	23	19	1,59	TNMC/TPMC 1603..	0,200
	STCN R/L 2020 K16	20	20	125	23	22	1,59	TNMC/TPMC 1603..	0,400
	STCN R/L 2525 M16	25	25	150	23	32	1,59	TNMC/TPMC 1603..	0,700
	STCN R/L 3232 P16	32	32	170	23	38	1,59	TNMC/TPMC 1603..	1,050
	STCN R/L 2020 K22	20	20	125	32	22	2,38	TNMC/TPMC 2204..	0,400
	STCN R/L 2525 M22	25	25	150	32	32	2,38	TNMC/TPMC 2204..	0,700
	STCN R/L 3225 P22	32	25	170	32	32	2,38	TNMC/TPMC 2204..	1,025
	STCN R/L 3232 P22	32	32	170	32	38	2,38	TNMC/TPMC 2204..	1,050
	STCN R/L 2525 M27	25	25	150	32	32	2,38	TNMC/TPMC 2704..	0,700
STCN R/L 3232 P27	32	32	170	32	38	2,38	TNMC/TPMC 2704..	1,050	

Ref.			
Ref.	STCN R/L 1212 F16	1935	5002
	STCN R/L 1616 H16	1935	5002
	STCN R/L 2020 K16	1935	5002
	STCN R/L 2525 M16	1935	5002
	STCN R/L 3232 P16	1935	5002
	STCN R/L 2020 K22	1950	5025
	STCN R/L 2525 M22	1950	5025
	STCN R/L 3225 P22	1950	5025
	STCN R/L 3232 P22	1950	5025
	STCN R/L 2525 M27	1955	5003
STCN R/L 3232 P27	1955	5003	

Ref.	TNMC/TPMC			Negative triangular inserts for threading
	l	s	d	
T..MC 1603..	16,50	3,18	9,52	For more information see page: H.10
T..MC 2204..	22,00	4,76	12,70	
T..MC 2704..	27,00	4,76	15,88	
	TNMC	TPMC		

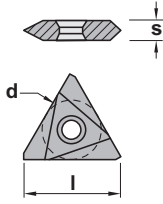

Threading
Drills
Cartridges
Brazed tools
Tooling

Inserts

General turning

Aluminium wheel turning

Automatic lathes

Ceramic tools

Parting and grooving

Threading

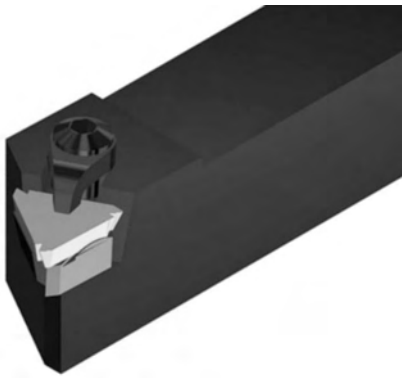

Characteristics:

Toolholder for flat positive inserts.
The insert is positioned with a 0° cutting angle, and a 0° clearance angle.

Applications:

Threading toolholder.

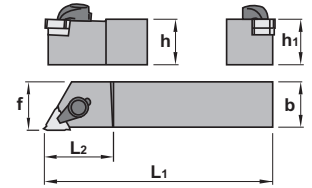
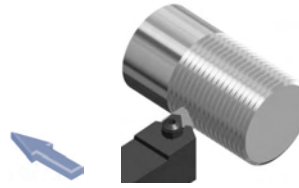

CXAP 90°

Ref.		h=h ₁	b	L ₁	L ₂	f	Insert size	Kg
CXAP R/L 2016 K16	CXAP R/L 2016 K16	20	16	125	22	17	R/L 166-3..	0,300
	CXAP R/L 2020 K16	20	20	125	28	21	R/L 166-3..	0,400
	CXAP R/L 2525 M16	25	25	150	28	26	R/L 166-3..	0,700
	CXAP R/L 3225 P16	32	25	170	28	26	R/L 166-3..	1,050
	CXAP R/L 3232 P16	32	32	170	28	33	R/L 166-3..	1,300
	CXAP R/L 2525 M22	25	25	150	34	26	R/L 166-4..	0,700
CXAP R/L 3225 P22	CXAP R/L 3225 P22	32	25	170	34	26	R/L 166-4..	1,050
	CXAP R/L 3232 P22	32	32	170	34	33	R/L 166-4..	1,300

Ref.							
CXAP R/L 2016 K16	CXAP R/L 2016 K16	2209	5003	3126 R/L	4012	2409	9216 - 9316
	CXAP R/L 2020 K16	2209	5003	3126 R/L	4012	2409	9216 - 9316
	CXAP R/L 2525 M16	2209	5003	3126 R/L	4012	2409	9216 - 9316
	CXAP R/L 3225 P16	2209	5003	3126 R/L	4012	2409	9216 - 9316
	CXAP R/L 3232 P16	2209	5003	3126 R/L	4012	2409	9216 - 9316
CXAP R/L 2525 M22	CXAP R/L 2525 M22	2211	5004	3132 R/L	4012	2411	9222 - 9322
	CXAP R/L 3225 P22	2211	5004	3132 R/L	4012	2411	9222 - 9322
	CXAP R/L 3232 P22	2211	5004	3132 R/L	4012	2411	9222 - 9322

Supplementary accessories

		R/L 166	l	s	d	Positive triangular inserts for threading
	Ref.	R/L 166-3..	16,50	3,18	9,52	For more information see page: H.11
		R/L 166-4..	22,00	4,76	12,70	
	R/L 166					



Characteristics:

Threading toolholder for negative lay down inserts.
The center screw ensures a good stiffness and evacuation of chips.
The insert is positioned with a -10° cutting angle, and a -1° clearance angle.

Applications:

Multipurpose threading boring bars.

Metric screws

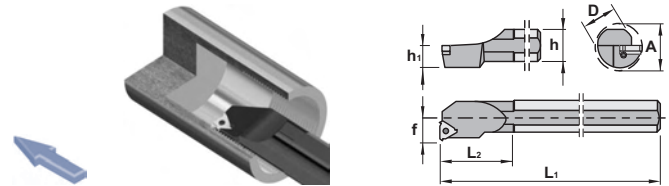

SXFN 90°

Ref.		D	h	h ₁	L ₁	L ₂	f	A	Insert size	Kg
S10K SXFN R/L 11		10	9	4,5	125	16	7,3	13	11 NR/L..	0,070
	S16M SXFN R/L 11	16	15	7,5	150	25	8,9	16	11 NR/L..	0,200
S16M SXFN R/L 16		16	15	7,5	150	25	11,5	20	16 NR/L..	0,200
S20Q SXFN R/L 16		20	18	9,0	180	25	13,4	24	16 NR/L..	0,400
S25S SXFN R/L 16		25	23	11,5	250	35	16,3	29	16 NR/L..	0,900
S32T SXFN R/L 16		32	30	15,0	300	40	19,6	36	16 NR/L..	1,750
S40T SXFN R/L 16		40	37	18,5	300	40	23,8	44	16 NR/L..	2,700
S20Q SXFN R/L 22		20	18	9,0	180	25	15,6	27	22 NR/L..	0,400
S25S SXFN R/L 22		25	23	11,5	250	35	17,2	32	22 NR/L..	0,900
S32T SXFN R/L 22		32	30	15,0	300	40	21,5	39	22 NR/L..	1,750
S40T SXFN R/L 22		40	37	18,5	300	40	25,8	47	22 NR/L..	2,700

Ref.					
S10K SXFN R/L 11	1225	5507	-	-	-
S16M SXFN R/L 11	1225	5507	-	-	-
S16M SXFN R/L 16	1635	5510	-	-	-
S20Q SXFN R/L 16	1334	5515	3425	3424	1093
S25S SXFN R/L 16	1335	5515	3425	3424	1093
S32T SXFN R/L 16	1335	5515	3425	3424	1093
S40T SXFN R/L 16	1335	5515	3425	3424	1093
S20Q SXFN R/L 22	1640	5515	-	-	-
S25S SXFN R/L 22	1340	5515	3431	3430	1094
S32T SXFN R/L 22	1340	5515	3431	3430	1094
S40T SXFN R/L 22	1340	5515	3431	3430	1094

 	N R/L			Negative triangular inserts for internal threading
	Ref.	l	d	
	11 NR/L..	11,00	6,35	
16 NR/L..	16,00	9,52		
22 NR/L..	22,00	12,70		
NR/L	NR/L TD			

For more information see page: H.05

Inserts

General turning

Aluminium wheel turning

Automatic lathes

Ceramic tools

Parting and grooving

Threading



Characteristics:
Boring bars with anti-vibration shank.

H-SXFN 90°

		D	h	h1	L1	L2	f	A	Insert size	
Ref.	H10K SXFN R/L 11	10	9	4,5	125	16	7,3	13	11 NR/L..	0,130
	H16M SXFN R/L 11	16	15	7,5	150	25	8,9	16	11 NR/L..	0,400
	H16M SXFN R/L 16	16	15	7,5	150	25	11,5	20	16 NR/L..	0,400
Ref.	H10K SXFN R/L 11			1225				5507		
	H16M SXFN R/L 11			1225				5507		
	H16M SXFN R/L 16			1635				5510		



Characteristics:
Boring bars with internal coolant and anti-vibration shank.

J-SXFN 90°

		D	h	h1	L1	L2	f	A	Insert size	
Ref.	J10K SXFN R/L 11	10	9	4,5	125	16	7,3	13	11 NR/L..	0,150
	J16M SXFN R/L 11	16	15	7,5	150	25	8,9	16	11 NR/L..	0,450
	J16M SXFN R/L 16	16	15	7,5	150	25	11,5	20	16 NR/L..	0,450
Ref.	J10K SXFN R/L 11			1225				5507		
	J16M SXFN R/L 11			1225				5507		
	J16M SXFN R/L 16			1635				5510		

	N R/L		l	d	Negative triangular inserts for internal threading For more information see page: H.05
	Ref.	11 NR/L..	11,00	6,35	
		16 NR/L..	16,00	9,52	
	NR/L	NR/L TD			



Characteristics:

Threading toolholder for negative lay down inserts.
The center screw ensures a good stiffness and evacuation of chips.
The insert is positioned with a -10° cutting angle, and a -1° clearance angle.

Applications:

Multipurpose threading boring bars.

Whitworth screws

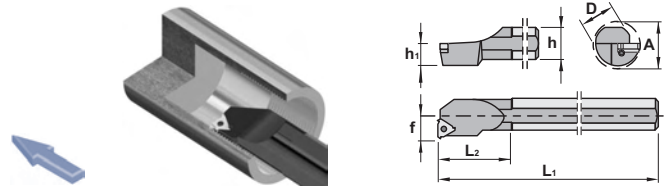

STXN 90°

Ref.		D	h	h ₁	L ₁	L ₂	f	A	Insert size	Kg
S16M STXN R/L 16	S16M STXN R/L 16	16	15	7,5	150	32	11,5	20	16 NR/L..	0,200
	S20Q STXN R/L 16	20	18	9,0	180	40	13,4	24	16 NR/L..	0,400
	S25R STXN R/L 16	25	23	11,5	200	45	16,3	29	16 NR/L..	0,700
	S32S STXN R/L 16	32	30	15,0	250	60	19,6	36	16 NR/L..	1,500
	S40T STXN R/L 16	40	37	18,5	300	60	23,8	44	16 NR/L..	2,850
	S20Q STXN R/L 22	20	18	9,0	180	50	15,6	27	22 NR/L..	0,400
	S25R STXN R/L 22	25	23	11,5	200	60	17,2	32	22 NR/L..	0,700
	S32S STXN R/L 22	32	30	15,0	250	60	21,5	39	22 NR/L..	1,500
	S40T STXN R/L 22	40	37	18,5	300	60	25,8	47	22 NR/L..	2,850
	S32S STXN R/L 27	32	30	15,0	250	60	22,4	40	27 NR/L..	1,500
S40T STXN R/L 27	40	37	18,5	300	60	26,4	48	27 NR/L..	2,850	
S50U STXN R/L 27	50	47	23,5	350	75	31,4	58	27 NR/L..	5,200	
S60V STXN R/L 27	60	57	28,5	400	75	36,4	69	27 NR/L..	8,550	

Ref.						
S16M STXN R/L 16	S16M STXN R/L 16	SN3	5510	-	-	-
	S20Q STXN R/L 16	SN3	5510	Y13	YE3	SY3
	S25R STXN R/L 16	SA3	5510	Y13	YE3	SY3
	S32S STXN R/L 16	SA3	5510	Y13	YE3	SY3
	S40T STXN R/L 16	SA3	5510	Y13	YE3	SY3
	S20Q STXN R/L 22	SN4	5520	-	-	-
	S25R STXN R/L 22	SA4	5520	Y14	YE4	SY4
	S32S STXN R/L 22	SA4	5520	Y14	YE4	SY4
	S40T STXN R/L 22	SA4	5520	Y14	YE4	SY4
	S32S STXN R/L 27	SA5	5525	Y15	YE5	SY5
S40T STXN R/L 27	SA5	5525	Y15	YE5	SY5	
S50U STXN R/L 27	SA5	5525	Y15	YE5	SY5	
S60V STXN R/L 27	SA5	5525	Y15	YE5	SY5	

	N R/L			Negative triangular inserts for internal threading
	Ref.	l	d	
	16 NR/L..	16,00	9,52	
22 NR/L..	22,00	12,70		
27 NR/L..	27,00	15,87		
For more information see page: H.05				
NR/L	NR/L TD			

Inserts

General turning

Aluminium wheel turning

Automatic lathes

Ceramic tools

Parting and grooving

Threading



Characteristics:

Top clamp threading toolholder for negative lay down inserts.
The top clamp ensures a good stiffness and evacuation of chips.
The insert is positioned with a -10° cutting angle, and a -1° clearance angle.

Applications:

Multipurpose threading boring bars.

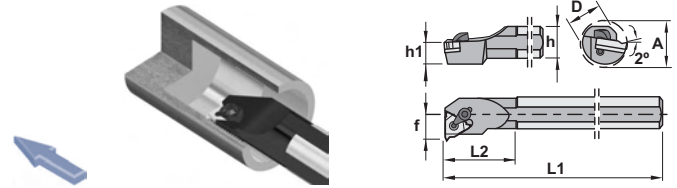

CTXN 90°

Ref.		D	h	h1	L1	L2	f	A	Insert size	Kg
S20Q CTXN R/L 16	S20Q CTXN R/L 16	20	18	9,0	180	50	13,0	18,0	16 NR/L..	0,400
	S25R CTXN R/L 16	25	23	11,5	200	45	17,0	22,6	16 NR/L..	0,700
	S32S CTXN R/L 16	32	30	15,0	250	60	22,0	29,0	16 NR/L..	1,500
	S40T CTXN R/L 16	40	37	18,5	300	60	27,0	36,0	16 NR/L..	2,850
S25R CTXN R/L 22	S25R CTXN R/L 22	25	23	11,5	200	45	17,0	22,6	22 NR/L..	0,700
	S32S CTXN R/L 22	32	30	15,0	250	60	22,0	29,0	22 NR/L..	1,500
	S40T CTXN R/L 22	40	37	18,5	300	60	27,0	36,0	22 NR/L..	2,850
S32S CTXN R/L 27	S32S CTXN R/L 27	32	30	15,0	250	60	22,4	40,0	27 NR/L..	1,500
	S40T CTXN R/L 27	40	37	18,5	300	60	26,4	48,0	27 NR/L..	2,850
S50U CTXN R/L 27	S50U CTXN R/L 27	50	47	23,5	350	75	31,4	58,0	27 NR/L..	5,200
S60V CTXN R/L 27	S60V CTXN R/L 27	60	58	29,0	400	75	36,4	69,0	27 NR/L..	8,550

Ref.							
S20Q CTXN R/L 16	2516	5515	YI3	YE3	SY3	SA3	SA3
S25R CTXN R/L 16	2516	5515	YI3	YE3	SY3	SA3	SA3
S32S CTXN R/L 16	2516	5515	YI3	YE3	SY3	SA3	SA3
S40T CTXN R/L 16	2516	5515	YI3	YE3	SY3	SA3	SA3
S25R CTXN R/L 22	2522	5515	YI4	YE4	SY4	SA4	SA4
S32S CTXN R/L 22	2522	5515	YI4	YE4	SY4	SA4	SA4
S40T CTXN R/L 22	2522	5515	YI4	YE4	SY4	SA4	SA4
S32S CTXN R/L 27	2527	5525	YI5	YE5	SY5	SA5	SA5
S40T CTXN R/L 27	2527	5525	YI5	YE5	SY5	SA5	SA5
S50U CTXN R/L 27	2527	5525	YI5	YE5	SY5	SA5	SA5
S60V CTXN R/L 27	2527	5525	YI5	YE5	SY5	SA5	SA5

Optional

Ref.	N R/L	l	d	Negative triangular inserts for internal threading
	16 NR/L..	16,00	9,52	
22 NR/L..	22,00	12,70		
27 NR/L..	27,00	15,87		

For more information see page: H.05

NR/L	NR/L TD				



Characteristics:

Vertical on edge threading toolholder.
The insert is positioned with a 0° cutting angle, and a 0° clearance angle.

Applications:

Threading boring bar.

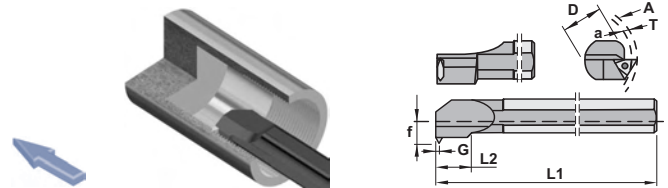

STGN 90°

Ref.		D	L1	L2	f	A	a	T	G	Insert size	Kg
S32U STGN R/L 16	S32U STGN R/L 16	32	350	19	21,0	50,4	45	2,7	1,59	TNMC 1603..	2,100
	S40V STGN R/L 16	40	400	19	25,0	60,4	55	2,7	1,59	TNMC 1603..	3,650
S32U STGN R/L 22	S32U STGN R/L 22	32	350	28	21,0	50,4	45	4,1	2,38	TNMC 2204..	2,100
	S40V STGN R/L 22	40	400	28	25,0	60,4	55	4,1	2,38	TNMC 2204..	3,650
	S50W STGN R/L 22	50	450	28	36,5	78,2	70	4,1	2,38	TNMC 2204..	6,700
S40V STGN R/L 27	S40V STGN R/L 27	40	400	28	25,0	60,4	55	6,0	3,18	TNMC 2704..	3,650
	S50W STGN R/L 27	50	450	28	36,5	78,2	70	6,0	3,18	TNMC 2704..	6,700

Ref.			
S32U STGN R/L 16	S32U STGN R/L 16	1935	5002
	S40V STGN R/L 16	1935	5002
S32U STGN R/L 22	S32U STGN R/L 22	1950	5025
	S40V STGN R/L 22	1950	5025
	S50W STGN R/L 22	1950	5025
S40V STGN R/L 27	S40V STGN R/L 27	1955	5003
	S50W STGN R/L 27	1955	5003

		TNMC				Triangular inserts for threading.
Ref.		l	s	d		
	TNMC 1603..	16,50	3,18	9,52		
	TNMC 2204..	22,00	4,76	12,70		
	TNMC 2704..	27,00	4,76	15,88		
For more information see page: H.10						
TNMC						

Inserts

General turning

Aluminium wheel turning

Automatic lathes

Ceramic tools

Parting and grooving

Threading



Characteristics:
Vertical on edge threading toolholder.
The insert is positioned with a 0° cutting angle, and a 0° clearance angle.
Applications:
Threading boring bar.

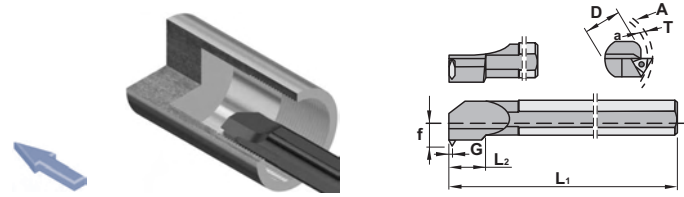

STGP 90°

Ref.		D	L1	L2	f	A	a	T	G	Insert size	Kg
S25T STGP R/L 16	S25T STGP R/L 16	25	300	19	17,5	50,4	45	2,7	1,59	TPMC 1603..	1,100
	S32U STGP R/L 16	32	350	19	20,5	50,4	45	2,7	1,59	TPMC 1603..	2,100
S40V STGP R/L 22	S40V STGP R/L 22	40	400	28	25,0	78,2	70	4,1	2,38	TPMC 2204..	3,650
	S50W STGP R/L 22	50	450	28	36,5	78,2	70	4,1	2,38	TPMC 2204..	6,700

Ref.			
S25T STGP R/L 16	S25T STGP R/L 16	1935	5002
	S32U STGP R/L 16	1935	5002
S40V STGP R/L 22	S40V STGP R/L 22	1950	5025
	S50W STGP R/L 22	1950	5025

Ref.	TPMC	l	s	d	Triangular inserts for threading.
	TPMC 1603..	16,50	3,18	9,52	
TPMC 2204..	22,00	4,76	12,70		
For more information see page: H.10					
TNMC					

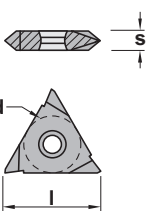



Characteristics:
 Threading toolholder for flat positive inserts.
 The insert is positioned with a 0° cutting angle, and a 0° clearance angle.

Applications:
 Threading boring bar.

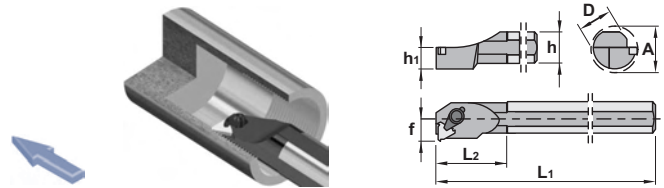

CXFP 90°

Ref.		D	h	h ₁	L ₁	L ₂	f	A	Insert size	/kg
S16R CXFP R/L 11	S16R CXFP R/L 11	16	15	7,5	200	30	11	20	R/L 166-2..	0,300
	S20S CXFP R/L 11	20	18	9,0	250	35	13	24	R/L 166-2..	0,550
S20S CXFP R/L 16	S20S CXFP R/L 16	20	18	9,0	250	35	13	24	R/L 166-3..	0,550
S25T CXFP R/L 16	S25T CXFP R/L 16	25	23	11,5	300	40	17	31	R/L 166-3..	1,050
S32U CXFP R/L 16	S32U CXFP R/L 16	32	30	15,0	350	50	22	39	R/L 166-3..	2,050
S40V CXFP R/L 22	S40V CXFP R/L 22	40	37	18,5	400	60	27	48	R/L 166-4..	3,650

Ref.			
S16R CXFP R/L 11	S16R CXFP R/L 11	2107	5025
	S20S CXFP R/L 11	2107	5025
S20S CXFP R/L 16	S20S CXFP R/L 16	2109	5003
S25T CXFP R/L 16	S25T CXFP R/L 16	2109	5003
S32U CXFP R/L 16	S32U CXFP R/L 16	2209	5003
S40V CXFP R/L 22	S40V CXFP R/L 22	2211	5004

		R/L 166	l	s	d	Positive triangular inserts for threading
	Ref.	R/L 166-2..	11,00	3,18	6,35	
		R/L 166-3..	16,50	3,18	9,52	
		R/L 166-4..	22,00	4,76	12,70	
For more information see page: H.11						
	R/L 166					

Cutting data

Material	Cutting speed m/min. (Ft/min) Tool grade		
	PM25	KM15	TIN25
Low and medium carbon steel	120-80 (390-260)		250-210 (820-690)
High carbon steel	110-70 (360-230)		210-150 (690-490)
Alloyed tool steel and heat-treatment steels	100-70 (360-230)		180-140 (590-460)
Stainless steels	100-70 (360-230)	90-70 (295-230)	140-110 (460-360)
Cast-iron HB 180-250		90-70 (295-230)	
Non-Ferrous metals		180-120 (590-390)	

N° of passes		
P mm	TPI	N° of passes
0,50	48,0	4 - 6
0,75	32,0	4 - 7
1,00	24,0	4 - 8
1,25	20,0	5 - 9
1,50	16,0	6 - 10
1,75	14,0	7 - 12
2,00	12,0	7 - 12
2,50	10,0	8 - 14
3,00	8,0	10 - 18
3,50	7,0	11 - 18
4,00	6,0	11 - 18
4,50	5,5	11 - 19
5,00	5,0	12 - 20
5,50	4,5	12 - 20
6,00	4,0	12 - 20
8,00	3,0	15 - 24

General recommendations:

- Threading speeds should normally be a minimum of 80% to 90% of turning speeds being used to machine the same component. (Assuming grades are compatible).
- Check helix angle and number of passes shown in charts before starting.
- Ensure centre height is correct.
- When there is a problem consult the following recommendations and change only one variable at time. This will help to be sure of the original problem.
- Do not use flank infeed on work hardening materials.

Component problems

	Problem	Cause and remedy
Pitch error (on CNC machines)	<ul style="list-style-type: none"> ★ Starting too close to workpiece ★ Saddle speed towards chuck is excessive 	<ul style="list-style-type: none"> ☆ Start cycle further back from workpiece. ☆ Reduce speed by 10% until correct.
Thread torn on one side only	<ul style="list-style-type: none"> ★ Incorrect helix angle in toolholder. 	<ul style="list-style-type: none"> ☆ Check helix chart. ☆ Reassemble with correct anvil. ☆ Check centre height.
Thread torn on both sides	<ul style="list-style-type: none"> ★ Running too slow. ★ Built up edge. 	<ul style="list-style-type: none"> ☆ Increase cutting speed. ☆ Check center height. ☆ Use coated grade. ☆ Compare thread speed with turning speed.
Long dangerous swarf	<ul style="list-style-type: none"> ★ Incorrect chipbreaker geometry. ★ Incorrect method of infeed. 	<ul style="list-style-type: none"> ☆ Use Canela (TD) chipbreaker. ☆ Use different infeed method.
Vibration chatter marks on both flanks	<ul style="list-style-type: none"> ★ Poor stability. ★ Excessive overhang. 	<ul style="list-style-type: none"> ☆ Renew anvil to support insert. ☆ Check tool clamping. ☆ Check rigidity of setup.
Shallow threads Problem with gauging	<ul style="list-style-type: none"> ★ Insert not cresting. ★ Incorrect effective diameter. 	<ul style="list-style-type: none"> ☆ Check machined diameters. ☆ Excessive tool wear or chipped on nose see remedies above.

Helix chart

Feed direction towards the chuck

RH Thread - RH Tool

LH Thread - LH Tool

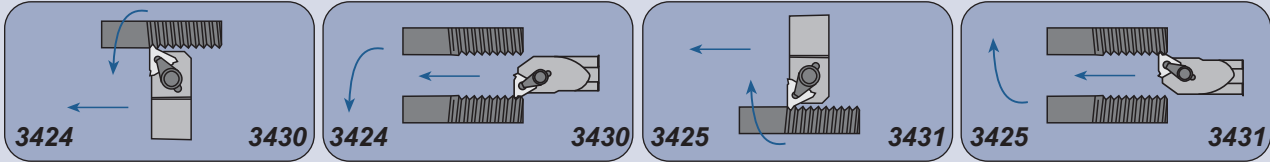

Anvil to give correct helix

Insert size	+3°	+2°	+1°	+0°
16R	3424+3	3424+2	3424+1	3424
16L	3425+3	3425+2	3425+1	3425
22R	3430+3	3430+2	3430+1	3430
22L	3431+3	3431+2	3431+1	3431

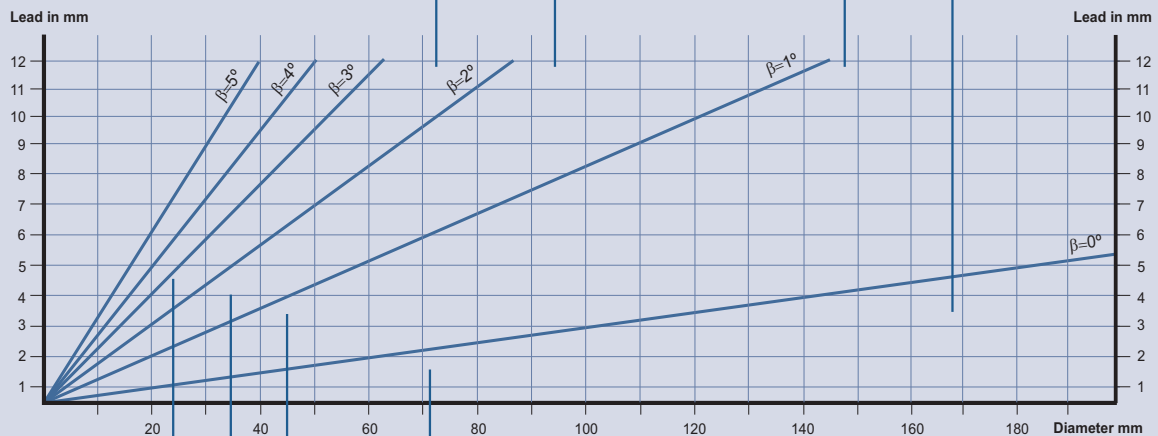
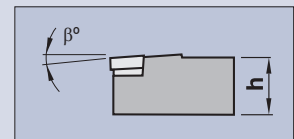

Anvil to give correct helix

Insert size	-3°	-2°	-1°	0°
16R	3424-3	3424-2	3424-1	3424
16L	3425-3	3425-2	3425-1	3425
22R	3430-3	3430-2	3430-1	3430
22L	3431-3	3431-2	3431-1	3431

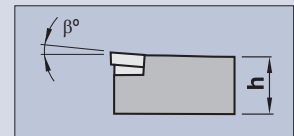

Feed direction away from the chuck

RH Thread - RH chuck

LH Thread - LH Tool

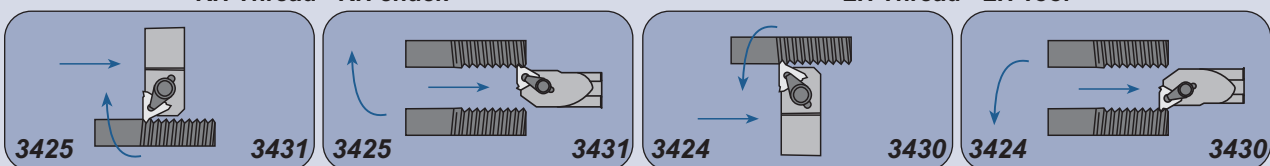

Inserts

General turning

Aluminium wheel turning

Automatic lathes

Ceramic tools

Parting and grooving

Threading

Threading insert wear and tool life

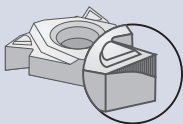
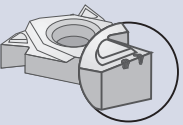
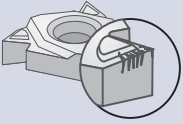
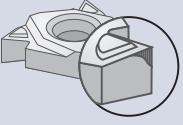
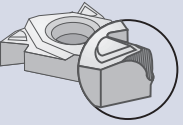
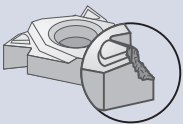
	Problem	Cause and Remedy
	<ul style="list-style-type: none"> ★ Cutting speed too high. ★ Lack of coolant. ★ Infeed per pass too small - too many passes ★ Incorrect grade. 	<ul style="list-style-type: none"> ☆ Reduce the cutting speed. ☆ Increase the coolant supply. ☆ Increase the depth of infeed for the smallest infeed depths - reduce the number of passes. ☆ Select a more wear resistant grade.
	<ul style="list-style-type: none"> ★ Instability of workholding and/or tool set-up. 	<ul style="list-style-type: none"> ☆ Check rigidity of operation. ☆ Select a tougher grade.
	<ul style="list-style-type: none"> ★ Intermittent coolant supply. 	<ul style="list-style-type: none"> ☆ Position coolant flow and/or increase coolant supply.
	<ul style="list-style-type: none"> ★ Incorrect method of infeed. ★ Incorrect angle of inclination. 	<ul style="list-style-type: none"> ☆ In case of flank infeed use modified flank infeed. Decrease infeed angle 3-5°. ☆ Correct the angle on inclination according to the diagram.
	<ul style="list-style-type: none"> ★ Infeed per pass too big - too few passes. ★ Lack of coolant. ★ Cutting speed too high. ★ Incorrect grade. ★ Excessive stock removal from crest. 	<ul style="list-style-type: none"> ☆ Decrease the depth of infeed for the biggest depths. - Increase the number of passes. ☆ Increase coolant supply. ☆ Reduce the cutting speed. ☆ Select a harder grade. ☆ Check the volume of the material above the crest.
	<ul style="list-style-type: none"> ★ Instability. ★ Lack of chip control. ★ Excessive plastic deformation. ★ Intermittent or inadequate coolant supply ★ Incorrect preparation of the operation 	<ul style="list-style-type: none"> ☆ Check rigidity of operation. ☆ Select a tougher grade. Select modified flank infeed. ☆ Machine with same infeed per pass. ☆ Direct coolant flow and/or increase coolant supply. ☆ Check dimension of blank.
<p>Shallow thread profile</p>	<ul style="list-style-type: none"> ★ Wrong centre height. ★ Insert not cresting. ★ Excessive tool wear. 	<ul style="list-style-type: none"> ☆ Adjust cutting edge height. ☆ Check dimension of blank. ☆ Change insert earlier.
<p>Incorrect thread profile</p>	<ul style="list-style-type: none"> ★ Incorrect tool setting. 	<ul style="list-style-type: none"> ☆ Correct tool setting.
<p>Lack of chip control</p>	<ul style="list-style-type: none"> ★ Incorrect depth of infeed per pass ★ Radial infeed. 	<ul style="list-style-type: none"> ☆ Adjust cutting edge height. ☆ Check dimension of blank. ☆ Change insert earlier.
<p>Bad surface finish</p>	<ul style="list-style-type: none"> ★ Cutting speed too low. ★ Incorrect angle of inclination. ★ Flank infeed. 	<ul style="list-style-type: none"> ☆ Increase the cutting speed. ☆ Correct the angle of inclination according to diagram. ☆ Use modified flank infeed or radial infeed.

