

Frese toriche elicoidali Z2 taglio al centro

Toroidal end mills 2 flutes center cutting

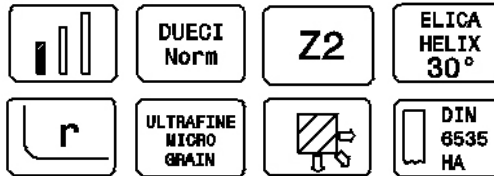
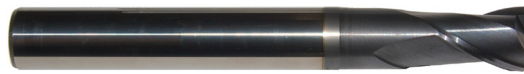
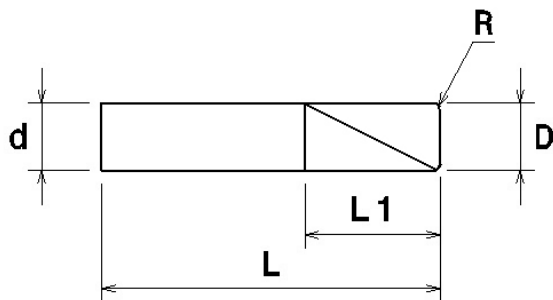

HSC

D _{h10}	L1	L	d _{h6}	R	Z	Cod.	€ uncoated	€ TiAlN	€ Advanced
2	6	60	2	0,5	2	AVC1002	14,00	17,10	24,10
3	8	60	3	0,5	2	AVC1003	17,20	20,30	27,30
4	10	60	4	0,5	2	AVC1004	18,10	21,70	28,20
5	10	60	5	0,5	2	AVC1005	19,60	24,50	31,80
6	10	60	6	1	2	AVC1006	22,30	27,20	34,50
8	12	75	8	1	2	AVC1008	31,50	37,40	45,60
10	18	75	10	1,5	2	AVC1010	40,50	47,70	56,90
12	18	100	12	1,5	2	AVC1012	62,90	71,90	82,20
16	24	100	16	2	2	AVC1016	100,50	110,20	121,10
18	24	100	18	2	2	AVC1018	125,00	136,50	148,70
20	38	104	20	2	2	AVC1020	160,70	178,70	195,50



D _{h10}	L1	L	d _{h6}	R	Z	Cod.	€ uncoated	€ TiAlN	€ Advanced
2	6	100	2	0,5	2	AVC1002L	15,80	19,80	27,60
3	8	100	3	0,5	2	AVC1003L	19,70	23,70	31,50
4	10	100	4	0,5	2	AVC1004L	21,20	25,90	33,00
4	10	150	4	0,5	2	AVC1004EL	25,00	34,00	43,70
5	10	100	5	0,5	2	AVC1005L	23,70	30,00	38,00
6	10	100	6	1	2	AVC1006L	27,70	34,10	42,10
6	10	150	6	1	2	AVC1006EL	34,50	45,70	56,70
8	12	100	8	1	2	AVC1008L	36,70	44,20	53,60
8	12	150	8	1	2	AVC1008EL	47,10	59,30	71,80
10	18	100	10	1,5	2	AVC1010L	48,00	56,90	67,30
10	18	150	10	1,5	2	AVC1010EL	62,90	76,80	90,50
12	18	150	12	1,5	2	AVC1012L	84,20	98,10	107,80
16	24	150	16	2	2	AVC1016L	136,10	151,80	166,80
18	24	150	18	2	2	AVC1018L	168,30	187,80	205,40
20	38	150	20	2	2	AVC1020L	210,90	237,80	260,70

A richiesta rivestimento **DLC** per rame, ottone e graffite
DLC coating for copper, brass and graphite on request

Frese toriche elicoidali Z4 taglio al centro

Toroidal end mills 4 flutes center cutting

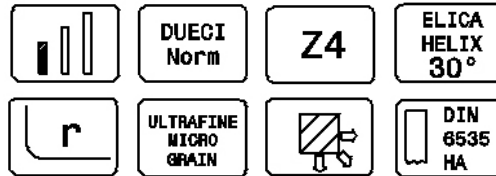
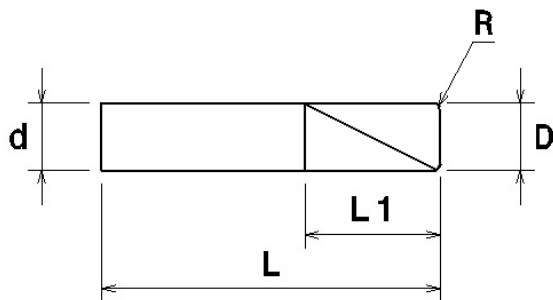

HSC

D _{h10}	L1	L	d _{h6}	R	Z	Cod.	€ uncoated	€ Tialn	€ Advanced
2	6	60	2	0,5	4	AVC1402	14,00	17,10	24,10
3	8	60	3	0,5	4	AVC1403	17,20	20,30	27,30
4	10	60	4	0,5	4	AVC1404	18,10	21,70	28,20
5	10	60	5	0,5	4	AVC1405	19,60	24,50	31,80
6	10	60	6	1	4	AVC1406	22,30	27,20	34,50
8	12	75	8	1	4	AVC1408	31,50	37,40	45,60
10	18	75	10	1,5	4	AVC1410	40,50	47,70	56,90
12	18	100	12	1,5	4	AVC1412	62,90	71,90	82,20
16	24	100	16	2	4	AVC1416	100,50	110,20	121,10
18	24	100	18	2	4	AVC1418	125,00	136,50	148,70
20	38	104	20	2	4	AVC1420	160,70	178,70	195,50



D _{h10}	L1	L	d _{h6}	R	Z	Cod.	€ uncoated	€ Tialn	€ Advanced
2	6	100	2	0,5	4	AVC1402L	15,80	19,80	27,60
3	8	100	3	0,5	4	AVC1403L	19,70	23,70	31,50
4	10	100	4	0,5	4	AVC1404L	21,20	25,90	33,00
4	10	150	4	0,5	4	AVC1404EL	25,00	34,00	43,70
5	10	100	5	0,5	4	AVC1405L	23,70	30,00	38,00
6	10	100	6	1	4	AVC1406L	27,70	34,10	42,10
6	10	150	6	1	4	AVC1406EL	34,50	45,70	56,70
8	12	100	8	1	4	AVC1408L	36,70	44,20	53,60
8	12	150	8	1	4	AVC1408EL	47,10	59,30	71,80
10	18	100	10	1,5	4	AVC1410L	48,00	56,90	67,30
10	18	150	10	1,5	4	AVC1410EL	62,90	76,80	90,50
12	18	150	12	1,5	4	AVC1412L	84,20	98,10	107,80
16	24	150	16	2	4	AVC1416L	136,10	151,80	166,80
18	24	150	18	2	4	AVC1418L	168,30	187,80	205,40
20	38	150	20	2	4	AVC1420L	210,90	237,80	260,70

A richiesta rivestimento **DLC** per rame, ottone e graffite
DLC coating for copper, brass and graphite on request

Frese toriche Z2 scaricate taglio al centro

Toroidal tapered end mills 2 flutes center cutting

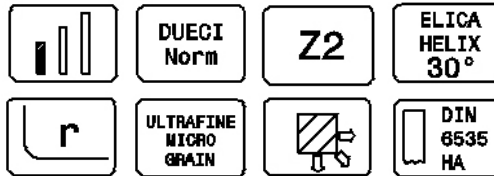
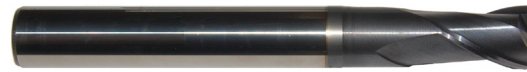
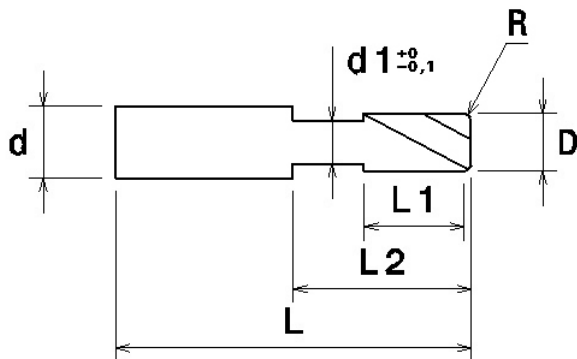

HSC

D _{h10}	L1	L2	L	d _{h6}	d1	R	Z	Cod.	€ uncoated	€ TiAlN	€ Advanced
2	6	12	60	6	1,9	0,5	2	AVT1002	26,10	31,10	38,30
3	8	14	60	6	2,9	0,5	2	AVT1003	26,10	31,10	38,30
4	10	18	60	6	3,9	0,5	2	AVT1004	26,10	31,10	38,30
5	10	20	60	6	4,9	0,5	2	AVT1005	26,10	31,10	38,30
6	10	24	60	6	5,9	1	2	AVT1006	23,90	28,80	36,00
8	12	30	75	8	7,8	1	2	AVT1008	33,70	39,60	47,90
10	18	30	75	10	9,6	1,5	2	AVT1010	42,70	50,00	59,10
12	18	38	100	12	11,6	1,5	2	AVT1012	65,20	74,10	84,50
16	24	44	100	16	15	2	2	AVT1016	102,80	112,40	123,30
18	24	44	100	18	17	2	2	AVT1018	127,20	138,80	150,90
20	38	58	104	20	19	2	2	AVT1020	162,90	180,90	197,70



D _{h10}	L1	L2	L	d _{h6}	d1	R	Z	Cod.	€ uncoated	€ TiAlN	€ Advanced
2	6	26	100	6	1,9	0,5	2	AVT1002L	31,50	37,90	45,90
3	8	28	100	6	2,9	0,5	2	AVT1003L	31,50	37,90	45,90
4	10	30	100	6	3,9	0,5	2	AVT1004L	31,50	37,90	45,90
4	10	30	150	6	3,9	0,5	2	AVT1004EL	38,30	49,50	60,50
5	10	30	100	6	4,9	0,5	2	AVT1005L	31,50	37,90	45,90
6	10	30	100	6	5,9	1	2	AVT1006L	29,30	35,60	43,70
6	10	30	150	6	5,9	1	2	AVT1006EL	36,00	47,30	58,20
8	12	32	100	8	7,8	1	2	AVT1008L	38,90	46,40	55,80
8	12	32	150	8	7,8	1	2	AVT1008EL	49,40	61,50	74,10
10	18	38	100	10	9,6	1,5	2	AVT1010L	50,20	59,20	69,50
10	18	38	150	10	9,6	1,5	2	AVT1010EL	65,20	79,00	92,70
12	18	38	150	12	11,6	1,5	2	AVT1012L	86,50	100,30	110,10
16	24	44	150	16	15	2	2	AVT1016L	138,40	154,10	169,00
18	24	44	150	18	17	2	2	AVT1018L	170,60	190,10	207,70
20	38	58	150	20	19	2	2	AVT1020L	213,10	240,10	262,90

A richiesta rivestimento **DLC** per rame, ottone e graffite
DLC coating for copper, brass and graphite on request

Frese toriche elicoidali Z4 scaricate taglio al centro

Toroidal tapered end mills 4 flutes center cutting

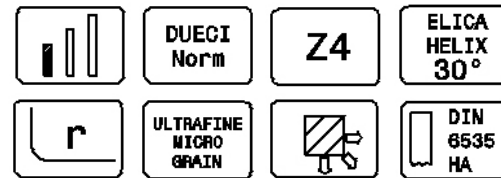
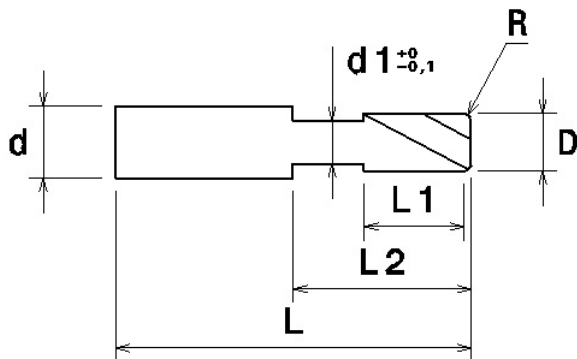

HSC

D _{h10}	L1	L2	L	d _{h6}	d1	R	Z	Cod.	€ uncoated	€ TiAlN	€ Advanced
2	6	12	60	6	1,9	0,5	4	AVT1402	26,10	31,10	38,30
3	8	14	60	6	2,9	0,5	4	AVT1403	26,10	31,10	38,30
4	10	18	60	6	3,9	0,5	4	AVT1404	26,10	31,10	38,30
5	10	20	60	6	4,9	0,5	4	AVT1405	26,10	31,10	38,30
6	10	24	60	6	5,9	1	4	AVT1406	23,90	28,80	36,00
8	12	30	75	8	7,8	1	4	AVT1408	33,70	39,60	47,90
10	18	30	75	10	9,6	1,5	4	AVT1410	42,70	50,00	59,10
12	18	38	100	12	11,6	1,5	4	AVT1412	65,20	74,10	84,50
16	24	44	100	16	15	2	4	AVT1416	102,80	112,40	123,30
18	24	44	100	18	17	2	4	AVT1418	127,20	138,80	150,90
20	38	58	104	20	19	2	4	AVT1420	162,90	180,90	197,70



D _{h10}	L1	L2	L	d _{h6}	d1	R	Z	Cod.	€ uncoated	€ TiAlN	€ Advanced
2	6	26	100	6	1,9	0,5	4	AVT1402L	31,50	37,90	45,90
3	8	28	100	6	2,9	0,5	4	AVT1403L	31,50	37,90	45,90
4	10	30	100	6	3,9	0,5	4	AVT1404L	31,50	37,90	45,90
4	10	30	150	6	3,9	0,5	4	AVT1404EL	38,30	49,50	60,50
5	10	30	100	6	4,9	0,5	4	AVT1405L	31,50	37,90	45,90
6	10	30	100	6	5,9	1	4	AVT1406L	29,30	35,60	43,70
6	10	30	150	6	5,9	1	4	AVT1406EL	36,00	47,30	58,20
8	12	32	100	8	7,8	1	4	AVT1408L	38,90	46,40	55,80
8	12	32	150	8	7,8	1	4	AVT1408EL	49,40	61,50	74,10
10	18	38	100	10	9,6	1,5	4	AVT1410L	50,20	59,20	69,50
10	18	38	150	10	9,6	1,5	4	AVT1410EL	65,20	79,00	92,70
12	18	38	150	12	11,6	1,5	4	AVT1412L	86,50	100,30	110,10
16	24	44	150	16	15	2	4	AVT1416L	138,40	154,10	169,00
18	24	44	150	18	17	2	4	AVT1418L	170,60	190,10	207,70
20	38	58	150	20	19	2	4	AVT1420L	213,10	240,10	262,90

A richiesta rivestimento **DLC** per rame, ottone e graffite
DLC coating for copper, brass and graphite on request

Frese toriche Z2 elica diritta taglio al centro

Toroidal end mills 2 straight flutes center cutting

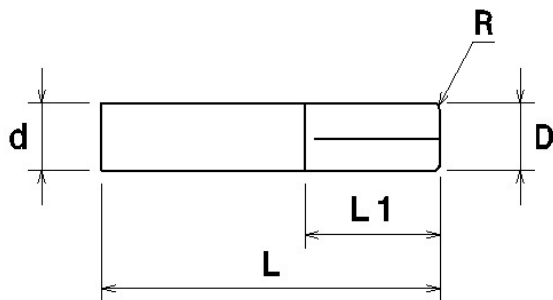

HSC

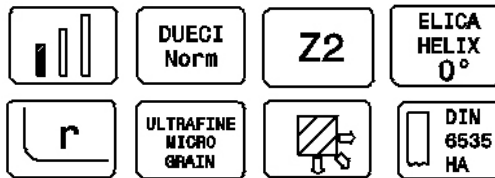

D _{h10}	L1	L	d _{h6}	R	Z	Cod.	€ uncoated	€ TiAlN	€ Advanced
2	6	60	2	0,5	2	AVC1002D	14,00	17,10	24,10
3	8	60	3	0,5	2	AVC1003D	17,20	20,30	27,30
4	10	60	4	0,5	2	AVC1004D	18,10	21,70	28,20
5	10	60	5	0,5	2	AVC1005D	19,60	24,50	31,80
6	10	60	6	1	2	AVC1006D	22,30	27,20	34,50
8	12	75	8	1	2	AVC1008D	31,50	37,40	45,60
10	18	75	10	1,5	2	AVC1010D	40,50	47,70	56,90
12	18	100	12	1,5	2	AVC1012D	62,90	71,90	82,20
16	24	100	16	2	2	AVC1016D	100,50	110,20	121,10
18	24	100	18	2	2	AVC1018D	125,00	136,50	148,70
20	38	104	20	2	2	AVC1020D	160,70	178,70	195,50



D _{h10}	L1	L	d _{h6}	R	Z	Cod.	€ uncoated	€ TiAlN	€ Advanced
2	6	100	2	0,5	2	AVC1002LD	15,80	19,80	27,60
3	8	100	3	0,5	2	AVC1003LD	19,70	23,70	31,50
4	10	100	4	0,5	2	AVC1004LD	21,20	25,90	33,00
4	10	150	4	0,5	2	AVC1004ELD	25,00	34,00	43,70
5	10	100	5	0,5	2	AVC1005LD	23,70	30,00	38,00
6	10	100	6	1	2	AVC1006LD	27,70	34,10	42,10
6	10	150	6	1	2	AVC1006ELD	34,50	45,70	56,70
8	12	100	8	1	2	AVC1008LD	36,70	44,20	53,60
8	12	150	8	1	2	AVC1008ELD	47,10	59,30	71,80
10	18	100	10	1,5	2	AVC1010LD	48,00	56,90	67,30
10	18	150	10	1,5	2	AVC1010ELD	62,90	76,80	90,50
12	18	150	12	1,5	2	AVC1012LD	84,20	98,10	107,80
16	24	150	16	2	2	AVC1016LD	136,10	151,80	166,80
18	24	150	18	2	2	AVC1018LD	168,30	187,80	205,40
20	38	150	20	2	2	AVC1020LD	210,90	237,80	260,70

A richiesta rivestimento **DLC** per rame, ottone e graffite
DLC coating for copper, brass and graphite on request

Frese toriche Z2 scaricate Elica diritta taglio al centro

Toroidal tapered end mills 2 straight flutes center cutting

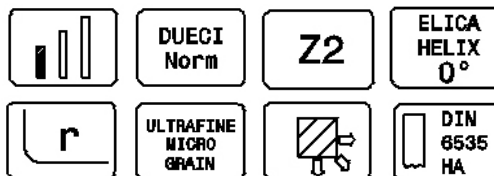
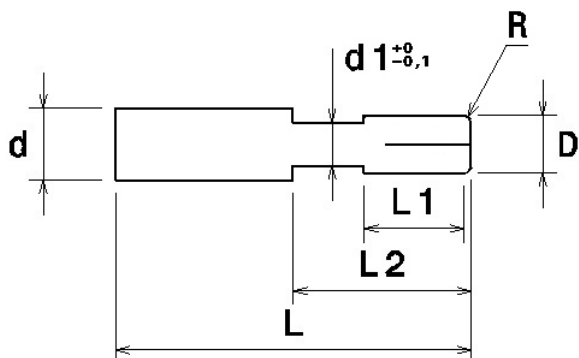

HSC

D _{h10}	L1	L2	L	d _{h6}	d1	R	Z	Cod.	€ uncoated	€ TiAlN	€ Advanced
2	6	12	60	6	1,9	0,5	2	AVT1002D	26,10	31,10	38,30
3	8	14	60	6	2,9	0,5	2	AVT1003D	26,10	31,10	38,30
4	10	18	60	6	3,9	0,5	2	AVT1004D	26,10	31,10	38,30
5	10	20	60	6	4,9	0,5	2	AVT1005D	26,10	31,10	38,30
6	10	24	60	6	5,9	1	2	AVT1006D	23,90	28,80	36,00
8	12	30	75	8	7,8	1	2	AVT1008D	33,70	39,60	47,90
10	18	30	75	10	9,6	1,5	2	AVT1010D	42,70	50,00	59,10
12	18	38	100	12	11,6	1,5	2	AVT1012D	65,20	74,10	84,50
16	24	44	100	16	15	2	2	AVT1016D	102,80	112,40	123,30
18	24	44	100	18	17	2	2	AVT1018D	127,20	138,80	150,90
20	38	58	104	20	19	2	2	AVT1020D	162,90	180,90	197,70



D _{h10}	L1	L2	L	d _{h6}	d1	R	Z	Cod.	€ uncoated	€ TiAlN	€ Advanced
2	6	26	100	6	1,9	0,5	2	AVT1002LD	31,50	37,90	45,90
3	8	28	100	6	2,9	0,5	2	AVT1003LD	31,50	37,90	45,90
4	10	30	100	6	3,9	0,5	2	AVT1004LD	31,50	37,90	45,90
4	10	30	150	6	3,9	0,5	2	AVT1004ELD	38,30	49,50	60,50
5	10	30	100	6	4,9	0,5	2	AVT1005LD	31,50	37,90	45,90
6	10	30	100	6	5,9	1	2	AVT1006LD	29,30	35,60	43,70
6	10	30	150	6	5,9	1	2	AVT1006ELD	36,00	47,30	58,20
8	12	32	100	8	7,8	1	2	AVT1008LD	38,90	46,40	55,80
8	12	32	150	8	7,8	1	2	AVT1008ELD	49,40	61,50	74,10
10	18	38	100	10	9,6	1,5	2	AVT1010LD	50,20	59,20	69,50
10	18	38	150	10	9,6	1,5	2	AVT1010ELD	65,20	79,00	92,70
12	18	38	150	12	11,6	1,5	2	AVT1012LD	86,50	100,30	110,10
16	24	44	150	16	15	2	2	AVT1016LD	138,40	154,10	169,00
18	24	44	150	18	17	2	2	AVT1018LD	170,60	190,10	207,70
20	38	58	150	20	19	2	2	AVT1020LD	213,10	240,10	262,90

A richiesta rivestimento **DLC** per rame, ottone e graffite
DLC coating for copper, brass and graphite on request

Frese raggiate Z2 elicoidali taglio al centro

Ball nose end mills 2 flutes center cutting

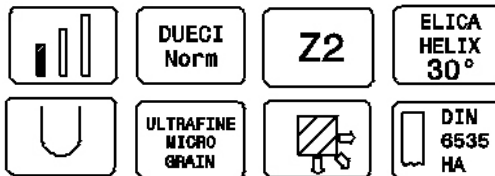
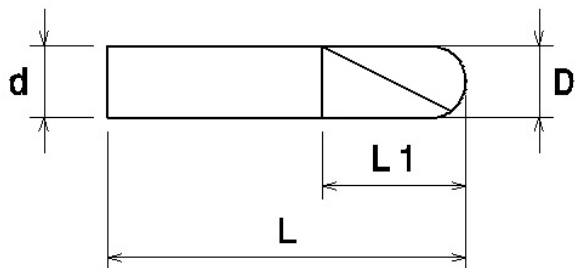

HSC

D _{h10}	L1	L	d _{h6}	Z	Cod.	€ uncoated	€ TiAlN	€ Advanced
2	6	60	2	2	AVC1002R	14,00	17,10	24,10
3	8	60	3	2	AVC1003R	17,20	20,30	27,30
4	10	60	4	2	AVC1004R	18,10	21,70	28,20
5	10	60	5	2	AVC1005R	19,60	24,50	31,80
6	10	60	6	2	AVC1006R	22,30	27,20	34,50
8	12	75	8	2	AVC1008R	31,50	37,40	45,60
10	18	75	10	2	AVC1010R	40,50	47,70	56,90
12	18	100	12	2	AVC1012R	62,90	71,90	82,20
16	24	100	16	2	AVC1016R	100,50	110,20	121,10
18	24	100	18	2	AVC1018R	125,00	136,50	148,70
20	38	104	20	2	AVC1020R	160,70	178,70	195,50



D _{h10}	L1	L	d _{h6}	Z	Cod.	€ uncoated	€ TiAlN	€ Advanced
2	6	100	2	2	AVC1002LR	15,80	19,80	27,60
3	8	100	3	2	AVC1003LR	19,70	23,70	31,50
4	10	100	4	2	AVC1004LR	21,20	25,90	33,00
4	10	150	4	2	AVC1004ELR	25,00	34,00	43,70
5	10	100	5	2	AVC1005LR	23,70	30,00	38,00
6	10	100	6	2	AVC1006LR	27,70	34,10	42,10
6	10	150	6	2	AVC1006ELR	34,50	45,70	56,70
8	12	100	8	2	AVC1008LR	36,70	44,20	53,60
8	12	150	8	2	AVC1008ELR	47,10	59,30	71,80
10	18	100	10	2	AVC1010LR	48,00	56,90	67,30
10	18	150	10	2	AVC1010ELR	62,90	76,80	90,50
12	18	150	12	2	AVC1012LR	84,20	98,10	107,80
16	24	150	16	2	AVC1016LR	136,10	151,80	166,80
18	24	150	18	2	AVC1018LR	168,30	187,80	205,40
20	38	150	20	2	AVC1020LR	210,90	237,80	260,70

A richiesta rivestimento **DLC** per rame, ottone e grafite
DLC coating for copper, brass and graphite on request

Frese raggiate Z2 elica diritta taglio al centro

Ball nose end mills 2 straight flutes center cutting

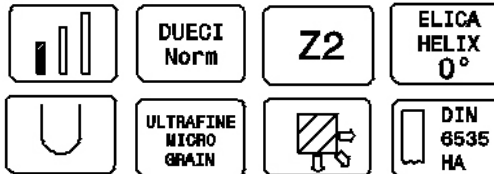
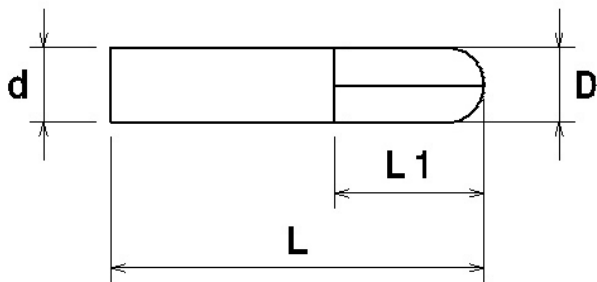

HSC

D _{h10}	L1	L	d _{h6}	Z	Cod.	€ uncoated	€ TiAlN	€ Advanced
2	6	60	2	2	AVC1002DR	14,00	17,10	24,10
3	8	60	3	2	AVC1003DR	17,20	20,30	27,30
4	10	60	4	2	AVC1004DR	18,10	21,70	28,20
5	10	60	5	2	AVC1005DR	19,60	24,50	31,80
6	10	60	6	2	AVC1006DR	22,30	27,20	34,50
8	12	75	8	2	AVC1008DR	31,50	37,40	45,60
10	18	75	10	2	AVC1010DR	40,50	47,70	56,90
12	18	100	12	2	AVC1012DR	62,90	71,90	82,20
16	24	100	16	2	AVC1016DR	100,50	110,20	121,10
18	24	100	18	2	AVC1018DR	125,00	136,50	148,70
20	38	104	20	2	AVC1020DR	160,70	178,70	195,50



D _{h10}	L1	L	d _{h6}	Z	Cod.	€ uncoated	€ TiAlN	€ Advanced
2	6	100	2	2	AVC1002LDR	15,80	19,80	27,60
3	8	100	3	2	AVC1003LDR	19,70	23,70	31,50
4	10	100	4	2	AVC1004LDR	21,20	25,90	33,00
4	10	150	4	2	AVC1004ELDR	25,00	34,00	43,70
5	10	100	5	2	AVC1005LDR	23,70	30,00	38,00
6	10	100	6	2	AVC1006LDR	27,70	34,10	42,10
6	10	150	6	2	AVC1006ELDR	34,50	45,70	56,70
8	12	100	8	2	AVC1008LDR	36,70	44,20	53,60
8	12	150	8	2	AVC1008ELDR	47,10	59,30	71,80
10	18	100	10	2	AVC1010LDR	48,00	56,90	67,30
10	18	150	10	2	AVC1010ELDR	62,90	76,80	90,50
12	18	150	12	2	AVC1012LDR	84,20	98,10	107,80
16	24	150	16	2	AVC1016LDR	136,10	151,80	166,80
18	24	150	18	2	AVC1018LDR	168,30	187,80	205,40
20	38	150	20	2	AVC1020LDR	210,90	237,80	260,70

A richiesta rivestimento **DLC** per rame, ottone e graffite
DLC coating for copper, brass and graphite on request

Frese sferiche Z2 scaricate taglio al centro

Nosed tapered end mills 2 flutes center cutting

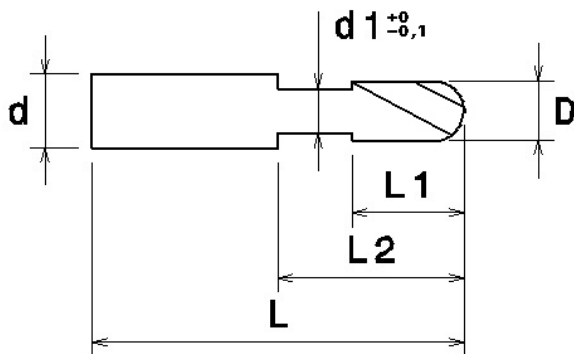

HSC

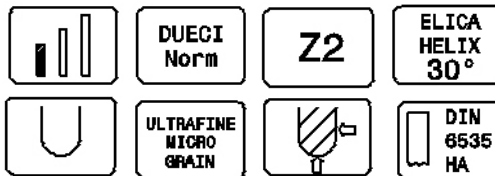

D _{h10}	L1	L2	L	d _{h6}	d1	Z	Cod.	€ uncoated	€ TiAlN	€ Advanced
2	6	12	60	6	1,9	2	AVR1102	26,10	31,10	38,30
3	8	14	60	6	2,9	2	AVR1103	26,10	31,10	38,30
4	10	18	60	6	3,9	2	AVR1104	26,10	31,10	38,30
5	10	20	60	6	4,9	2	AVR1105	26,10	31,10	38,30
6	10	24	60	6	5,9	2	AVR1106	23,90	28,80	36,00
8	12	30	75	8	7,8	2	AVR1108	33,70	39,60	47,90
10	18	30	75	10	9,6	2	AVR1110	42,70	50,00	59,10
12	18	38	100	12	11,6	2	AVR1112	65,20	74,10	84,50
16	24	44	100	16	15	2	AVR1116	102,80	112,40	123,30
18	24	44	100	18	17	2	AVR1118	127,20	138,80	150,90
20	38	58	104	20	19	2	AVR1120	162,90	180,90	197,70



D _{h10}	L1	L2	L	d _{h6}	d1	Z	Cod.	€ uncoated	€ TiAlN	€ Advanced
2	6	26	100	6	1,9	2	AVR1102L	31,50	37,90	45,90
3	8	28	100	6	2,9	2	AVR1103L	31,50	37,90	45,90
4	10	30	100	6	3,9	2	AVR1104L	31,50	37,90	45,90
4	10	30	150	6	3,9	2	AVR1104EL	38,30	49,50	60,50
5	10	30	100	6	4,9	2	AVR1105L	31,50	37,90	45,90
6	10	30	100	6	5,9	2	AVR1106L	29,30	35,60	43,70
6	10	30	150	6	5,9	2	AVR1106EL	36,00	47,30	58,20
8	12	32	100	8	7,8	2	AVR1108L	38,90	46,40	55,80
8	12	32	150	8	7,8	2	AVR1108EL	49,40	61,50	74,10
10	18	38	100	10	9,6	2	AVR1110L	50,20	59,20	69,50
10	18	38	150	10	9,6	2	AVR1110EL	65,20	79,00	92,70
12	18	38	150	12	11,6	2	AVR1112L	86,50	100,30	110,10
16	24	44	150	16	15	2	AVR1116L	138,40	154,10	169,00
18	24	44	150	18	17	2	AVR1118L	170,60	190,10	207,70
20	38	58	150	20	19	2	AVR1120L	213,10	240,10	262,90

A richiesta rivestimento **DLC** per rame, ottone e graffite
DLC coating for copper, brass and graphite on request

Frese sferiche Z2 scaricate elica diritta taglio al centro

Nosed tapered end mills 2 straight flutes center cutting

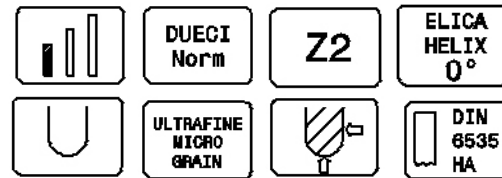
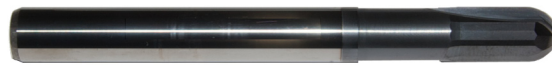
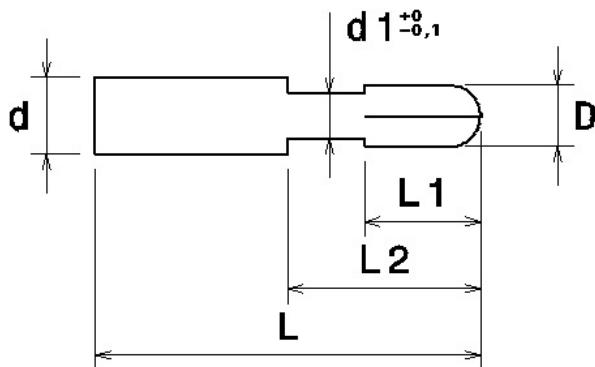

HSC

D _{h10}	L1	L2	L	d _{h6}	d1	Z	Cod.	€ uncoated	€ TiAlN	€ Advanced
2	6	12	60	6	1,9	2	AVR1102D	26,10	31,10	38,30
3	8	14	60	6	2,9	2	AVR1103D	26,10	31,10	38,30
4	10	18	60	6	3,9	2	AVR1104D	26,10	31,10	38,30
5	10	20	60	6	4,9	2	AVR1105D	26,10	31,10	38,30
6	10	24	60	6	5,9	2	AVR1106D	23,90	28,80	36,00
8	12	30	75	8	7,8	2	AVR1108D	33,70	39,60	47,90
10	18	30	75	10	9,6	2	AVR1110D	42,70	50,00	59,10
12	18	38	100	12	11,6	2	AVR1112D	65,20	74,10	84,50
16	24	44	100	16	15	2	AVR1116D	102,80	112,40	123,30
18	24	44	100	18	17	2	AVR1118D	127,20	138,80	150,90
20	38	58	104	20	19	2	AVR1120D	162,90	180,90	197,70



D _{h10}	L1	L2	L	d _{h6}	d1	Z	Cod.	€ uncoated	€ TiAlN	€ Advanced
2	6	26	100	6	1,9	2	AVR1102LD	31,50	37,90	45,90
3	8	28	100	6	2,9	2	AVR1103LD	31,50	37,90	45,90
4	10	30	100	6	3,9	2	AVR1104LD	31,50	37,90	45,90
4	10	30	150	6	3,9	2	AVR1104ELD	38,30	49,50	60,50
5	10	30	100	6	4,9	2	AVR1105LD	31,50	37,90	45,90
6	10	30	100	6	5,9	2	AVR1106LD	29,30	35,60	43,70
6	10	30	150	6	5,9	2	AVR1106ELD	36,00	47,30	58,20
8	12	32	100	8	7,8	2	AVR1108LD	38,90	46,40	55,80
8	12	32	150	8	7,8	2	AVR1108ELD	49,40	61,50	74,10
10	18	38	100	10	9,6	2	AVR1110LD	50,20	59,20	69,50
10	18	38	150	10	9,6	2	AVR1110ELD	65,20	79,00	92,70
12	18	38	150	12	11,6	2	AVR1112LD	86,50	100,30	110,10
16	24	44	150	16	15	2	AVR1116LD	138,40	154,10	169,00
18	24	44	150	18	17	2	AVR1118LD	170,60	190,10	207,70
20	38	58	150	20	19	2	AVR1120LD	213,10	240,10	262,90

A richiesta rivestimento **DLC** per rame, ottone e graffite
DLC coating for copper, brass and graphite on request

Frese Z2 sferiche raccordo conico taglio al centro

Nosed tapered end mills 2 flutes center cutting

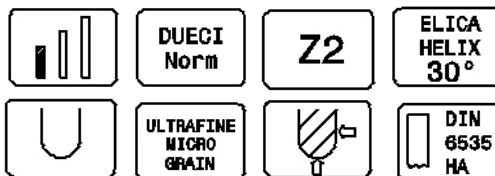
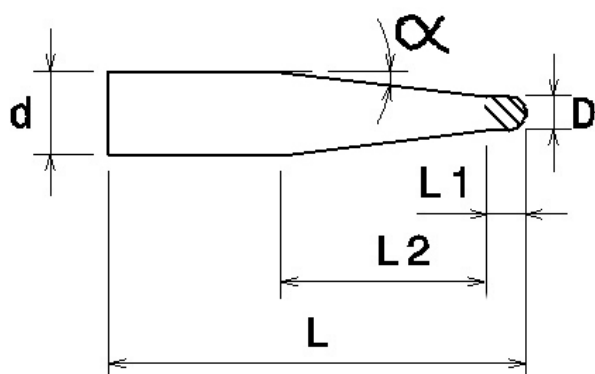

HSC

D h10	L1	L2	L	d h6	α	Z	Cod.	€ uncoated	€ TiAlN	€ Advanced
2	4	30	75	6	4°	2	AVRC1102	28,40	33,30	40,50
3	4	30	75	6	3°	2	AVRC1103	28,40	33,30	40,50
4	5	30	75	6	2°	2	AVRC1104	26,10	31,10	38,30
5	6	30	75	6	1°	2	AVRC1105	26,10	31,10	38,30
6	8	28	75	10	4°	2	AVRC1106	38,30	45,50	54,60
8	12	38	100	10	2°	2	AVRC1108	49,50	58,40	68,80
10	15	35	100	12	2°	2	AVRC1110	76,50	85,40	95,80
12	15	35	100	16	3°	2	AVRC1112	111,80	121,40	132,30



D h10	L1	L2	L	d h6	α	Z	Cod.	€ uncoated	€ TiAlN	€ Advanced
2	4	45	100	6	2,5°	2	AVRC1102L	33,80	40,10	46,00
3	4	45	100	6	3°	2	AVRC1103L	33,80	40,10	46,00
4	5	45	100	6	1,5°	2	AVRC1104L	30,00	36,30	42,20
5	6	45	100	6	0,7°	2	AVRC1105L	30,00	36,30	42,20
6	8	45	100	10	3°	2	AVRC1106L	52,50	61,40	68,90
8	12	65	150	10	2°	2	AVRC1108L	72,00	85,80	91,20
10	15	65	150	12	1°	2	AVRC1110L	97,80	111,60	117,00
12	15	65	150	16	2°	2	AVRC1112L	147,40	163,00	167,90

A richiesta rivestimento **DLC** per rame, ottone e grafite
DLC coating for copper, brass and graphite on request

Frese Z2 sferiche raccordo conico taglio al centro elica diritta

Nosed tapered end mills 2 straight flutes center cutting

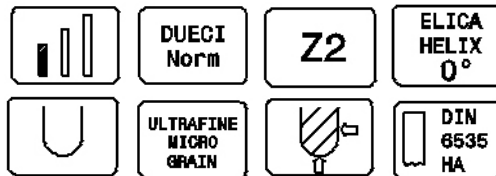
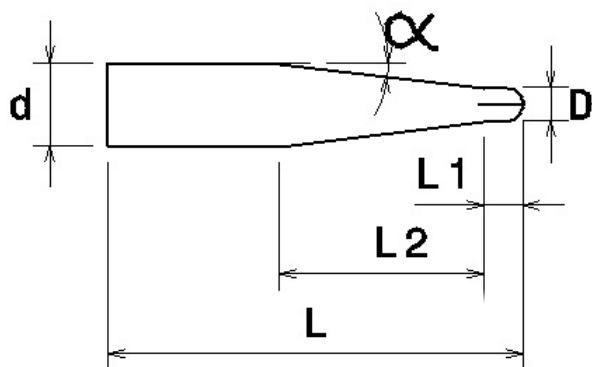

HSC

D h10	L1	L2	L	d h6	α	Z	Cod.	€ uncoated	€ TiAlN	€ Advanced
2	4	30	75	6	4°	2	AVRC1102D	28,40	33,30	40,50
3	4	30	75	6	3°	2	AVRC1103D	28,40	33,30	40,50
4	5	30	75	6	2°	2	AVRC1104D	26,10	31,10	38,30
5	6	30	75	6	1°	2	AVRC1105D	26,10	31,10	38,30
6	8	28	75	10	4°	2	AVRC1106D	38,30	45,50	54,60
8	12	38	100	10	2°	2	AVRC1108D	49,50	58,40	68,80
10	15	35	100	12	2°	2	AVRC1110D	76,50	85,40	95,80
12	15	35	100	16	3°	2	AVRC1112D	111,80	121,40	132,30



D h10	L1	L2	L	d h6	α	Z	Cod.	€ uncoated	€ TiAlN	€ Advanced
2	4	45	100	6	2,5°	2	AVRC1102LD	33,80	40,10	46,00
3	4	45	100	6	3°	2	AVRC1103LD	33,80	40,10	46,00
4	5	45	100	6	1,5°	2	AVRC1104LD	30,00	36,30	42,20
5	6	45	100	6	0,7°	2	AVRC1105LD	30,00	36,30	42,20
6	8	45	100	10	3°	2	AVRC1106LD	52,50	61,40	68,90
8	12	65	150	10	2°	2	AVRC1108LD	72,00	85,80	91,20
10	15	65	150	12	1°	2	AVRC1110LD	97,80	111,60	117,00
12	15	65	150	16	2°	2	AVRC1112LD	147,40	163,00	167,90

A richiesta rivestimento **DLC** per rame, ottone e grafite
DLC coating for copper, brass and graphite on request

Frese toriche multitagliante

Toroidal multi flutes end mills

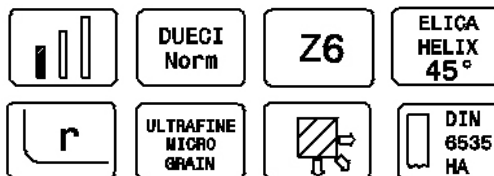
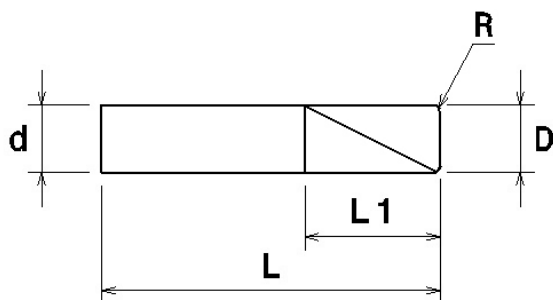

HSC

D _{h10}	L1	L	d _{h6}	Z	R	Cod.	€ uncoated	€ Tialn	€ TopTialn
6	20	60	6	6	1	AVTM06	35,60	40,20	46,90
8	25	80	8	6	1	AVTM08	45,60	52,60	61,40
10	30	80	10	6	1,5	AVTM10	58,40	66,70	76,40
12	35	100	12	6	1,5	AVTM12	79,80	88,20	97,90
16	40	100	16	6	2	AVTM16	114,50	123,50	133,70
18	40	100	18	6	2	AVTM18	136,90	147,70	159,00
20	40	104	20	6	2	AVTM20	165,90	182,70	198,30



D _{h10}	L1	L	d _{h6}	Z	R	Cod.	€ uncoated	€ Tialn	€ TopTialn
6	24	100	6	6	1	AVTM06L	42,60	48,60	56,00
8	32	100	8	6	1	AVTM08L	53,50	60,50	69,30
10	32	100	10	6	1,5	AVTM10L	66,00	74,30	84,00
12	50	150	12	6	1,5	AVTM12L	103,70	116,60	129,40
16	60	150	16	6	2	AVTM16L	155,70	170,30	184,30
18	60	150	18	6	2	AVTM18L	185,40	203,60	220,00
20	60	150	20	6	2	AVTM20L	222,70	247,90	269,20