

BRC-TM / BRC-TT





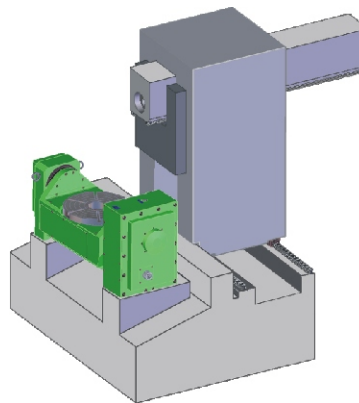

Tavole roto-basculanti torque Torque tilting rotary table

Specifiche per macchine a 5 assi
Motori coppia
Bloccaggio idraulico

Designed and made for 5 axis machines
Torque motor
Hydraulic clamping



Caratteristiche - Modelli Specifications - Models		BRC-TM 400	BRC-TT 600		
Diámetro tavola Table diameter	mm.	400	600		
Diámetro massimo pezzo Max diameter of workpiece	mm.	520	860		
Larghezza cave a T Table T-slot width	mm.	14	14		
Inclinazione Tilt range		-110° ÷ 110°		-120° ÷ 120°	
Asse Axis		Girevole Rotary	Inclinabile Tilting	Girevole Rotary	Inclinabile Tilting
Sistema di bloccaggio Clamp system		Idraulico Hydraulic	Idraulico Hydraulic	Idraulico Hydraulic	Idraulico Hydraulic
Capacità di bloccaggio Clamp torque	Nm.	1200 (60 Bar)	3100 (60 Bar)	2500 (40 Bar)	4500 (40 Bar)
Rapporto asse/motore Axis/motor ratio		1/1	1/180	1/1	1/1
Grandezza motore (pagina 43) Servo motor size (page 43)		Coppia Torque	5	Coppia Torque	Coppia Torque
Velocità massima di rotazione Max rotation speed	Rpm	90	16,6	120	60
Precisione di posizionamento* Indexing accuracy	sec.	± 5	± 25	± 5	± 5
Coppia di lavoro Working torque	 Nm	536 (S1)	1500	620 (S1)	1600 (S1)
Peso max ammesso 0° Allowable work weight 0°	 Kg.	400	500		
Spinta max ammessa 0° Allowable load 0°	 N.	15000	22000		
Spinta max ammessa 90° Allowable load 90°	 FxL Nm	3100	4500		
Peso netto tavola Table net weight	Kg.	550	1400		

*Le tavole serie BRC-TM / BRC-TT sono predisposte per l'installazione di encoder ad alta risoluzione (fino a ±2,5") su entrambe gli assi. Possono inoltre essere dotate di distributore idraulico/pneumatico per la gestione di eventuali attrezzature di presa installate sul piano tavola.

*The BRC-TM / BRC-TT table series are prepared for installation of high resolution encoders (up to ±2,5") on both axis. They can also be equipped with hydraulic/pneumatic distributor for the control of any workholding equipment installed on the table surface.

Tavole roto-basculanti torque
Torque tilting rotary table

Motore coppia
Torque motor



Specifiche per a 5 assi
Motori coppia
Bloccaggio idraulico

Designed and made for 5 axis machines
Torque motors
Hydraulic clamping

BRC-TM 400

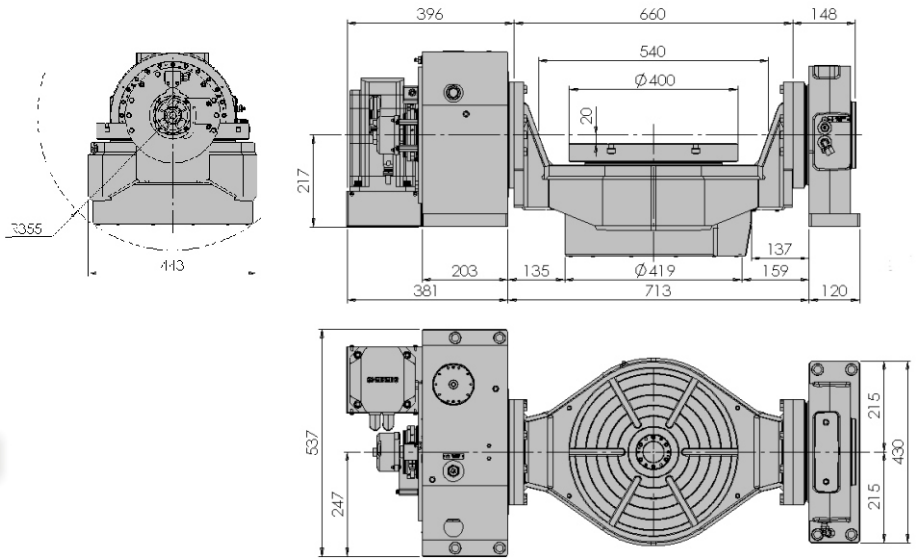

BRC-TT 600

